



SERIES 3E

PN 6/10/16/25/40 // Class 150/300

DN 80–400 (NPS 3–16)

-100 °C to 500 °C (148 °F to 936 °F)

Oil and Gas

Power Generation

Processing Industry



CE

TRIPLE OFFSET BUTTERFLY VALVES

WWW.ABOVALVE.COM

GENERAL INFORMATION

GENERAL CHARACTERISTICS

- DN 80–400 (NPS 3–16)
- Triple offset design
- Minimal opening, closing friction
- Metal / metal seat
- High temperature applications
- Shut-off and regulating device
- Easy repair and maintenance
- High-performance applications
- Fire-safe and ATEX versions available
- Reliability and long service life

APPLICATIONS

High performance applications such as steam, chilled water, gasoline, oil, jet fuels, natural gas, utility lines, process lines and in industries such as:

- Power Generation
- Oil and Gas
- Refineries
- Chemical and Petrochemical
- Steel and Mining
- Pulp and Paper
- Food and Beverage

WHY CHOOSE A TRIPLE OFFSET VALVE?

- Valves can be used for demanding long-term applications up to 500 °C (932 °F)
- Valves designed to withstand high pressures up to 50 bar (725 psi).
- Friction in the seat is almost eliminated during the control cycle, which significantly improves service life of the device.
- Simple maintenance and repairs thanks to a replaceable sealing ring in the closure/body and a removable seat ring*.

* Only available for F body type DN 150 (NPS 6) and above

STANDARDS

LEAK TEST:

- EN 12266-1, Rate A/B*
- ISO 5208, Rate A/B*
- API 598, Table 5
- ANSI/FCI 70-2, Class VI

* For tightness rate A, please consult with the manufacturer.

FACE TO FACE DIMENSIONS:

- Body type B and T (wafer and lug):
- EN 558, Series 20
 - ISO 5752, Series 20
 - API 609, Category B

Body type F (double flanged):

- EN 558, Series 13
- ISO 5752, Series 13
- API 609, Category B (short pattern)

CONNECTION BETWEEN FLANGES:

- EN 1092-1,2
- ASME B16.5

ATEX OPTION:

- Zone - 0, 1, 20, 21
- Mining area Group I Category M1
- Group II Category 1G/2GD TX

WORKING STANDARD:

- EN 593 + A1
- API 609

TOP FLANGE:

- EN ISO 5211

MARKING:

- EN 19
- MSS SP-25

FIRE-SAFE OPTION:

- ISO 10497
- API 607

TYPE DESIGNATION

3E – 3 5 L 4 B 150

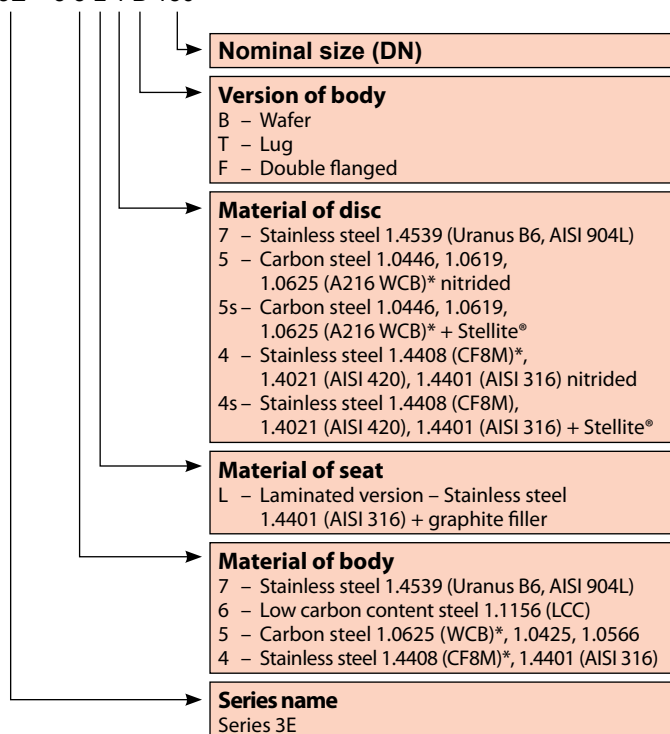

* Material options for double flanged (F type) body valves

MODELS

Wafer type B



Lug type T

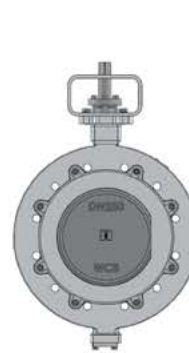

Double flanged type F

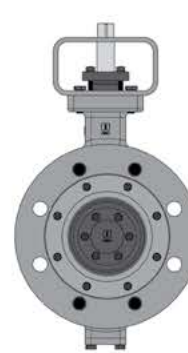

PRODUCT QUALITY AND CONTROL

- ABO production facilities are certified in accordance to ISO 9001 (ISO 14001, OHSAS 18001) quality system
- Test procedures are established according to: ANSI/FCI 70-2, API 598, ISO 5208, EN 12266-1
- Manufacture according to the requirements of the European Directive 2014/68/EU – Equipment under pressure (Category III, Module H)
- All ABO valves pass pressure tests to 110% of rated pressure to ensure bubble tight shutoff
- All actuators are calibrated and cycle tested before shipment
- Material Traceability Rule – Certification is provided for all supplied valves on customer request
- Positive Material Identification – All materials are subjected to PMI testing in order to verify Material Traceability
- API 609 Monogram can be placed on the valve upon request
- Certificates – A complete list of certificates can be found on www.abovalve.com.

DESIGN BENEFITS OF WAFER AND LUG TRIPLE OFFSET VALVES



GRAPHITE RING PACKING SYSTEM

The packing system consists of a series of soft graphite sealing rings preventing leakage around the shaft. Graphite is a material which perfectly seals and resists high temperatures. Optimization of the ratio between tightness around the shaft and the actuating torque can be easily achieved by tightening or loosening the nuts holding the packing flange.

INTERNATIONAL STANDARD COMPATIBILITY

Top flange according to ISO 5211 enables direct mounting of manual operators and actuators. Longer neck of ABO butterfly valves results in insulation of ISO top flange, for protection of mounted actuator and meeting heating system requirements.

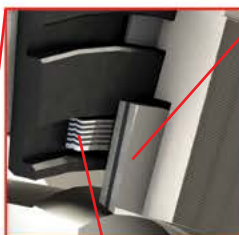

LAMINATED SEAT

A sealing ring, ensuring tightness in the seat, forms a sandwich of stainless steel sheets layered with a soft filler of graphite. This composition is able to withstand high temperatures and ensures excellent resilience of the sealing element even during significant fluctuations of medium temperature and pressure.

SPIRAL GASKET

Spirally wound stainless steel band with a soft graphite filler guarantees a perfect seal even with large temperature and pressure fluctuations inside the pipe.



SPLIT SHAFT

The split shaft significantly reduces pressure drops and provides favorable Kv (Cv) values. Lower pressure losses mean lower energy consumption, which leads to savings.

TRIPLE OFFSET

The ABO triple offset design ensures safe function and tightness even in case of changing temperatures or in case of pressure peak. It also eliminates friction in the seat area when opening and closing the valve, minimizing wear of the sealing elements, and significantly prolonging the service life of the valve. The first offset shifts the axis of the shaft rotation off the plane that lies on the pipeline axis. The second offset moves the center plane of the closing element parallel to its flat surface outside of the axis of its rotation. The third offset deflects the axis of rotational symmetry of the seat surface outside of the axis perpendicular to the flat surface of the disc, running through its center. A set of all these offsets results in specific valve properties such as friction elimination during opening/closing cycle, ideal contact of disc and seat in closed position and its sophisticated geometry naturally prevents the disc from moving beyond the safe limit and directly defines the correct alignment of sealing elements.

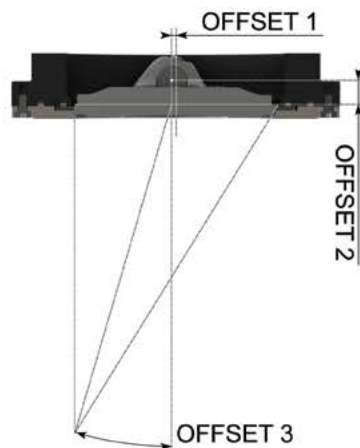

MATERIALS AND TECHNICAL INFORMATION

DRAWING AND MATERIALS

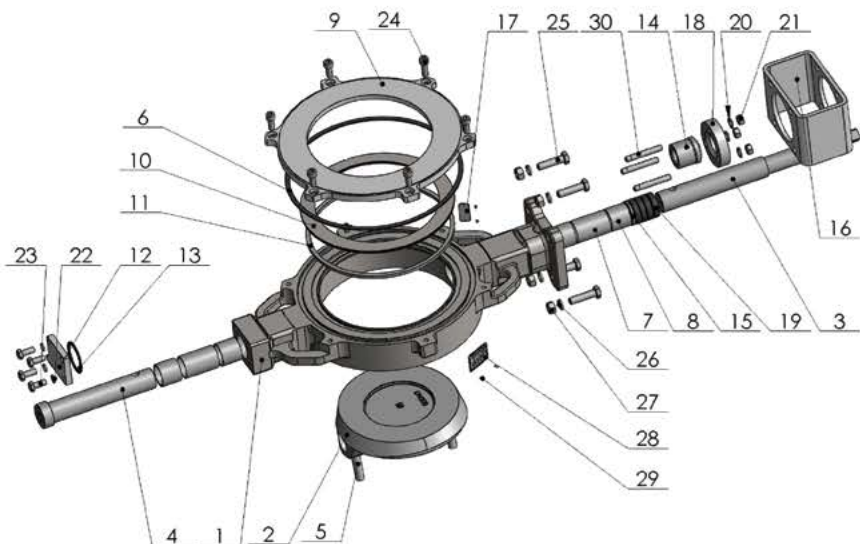

Execution in other material types can be provided upon request. Choice of the seat and disc materials for various media will be recommended upon specific inquiry.

Item	Name	Material
1	Body	7 – Stainless steel 1.4539 (Uranus B6/AISI 904L)
		6 – Low carbon content steel 1.1156 (A352 LCC)
		5 – Carbon Steel 1.0625 (A216 WCB)
		4 – Stainless Steel 1.4408 (A351 CF8M)
2	Disc	7 – Stainless steel 1.4539 (Uranus B6/AISI 904L)
		5 – Carbon steel 1.0446, 1.0619, 1.0625 (A216 WCB) nitrided
		5s – Carbon steel 1.0446, 1.0619, 1.0625 (A216 WCB) + Stellite®
		4 – Stainless steel 1.4401 (AISI 316) – for stainless steel body up to DN 300
		Stainless steel 1.4021 (AISI 420) – for WCB body DN 350–400
3	Shaft	Stainless steel 1.4021 (AISI 420)/ 1.4462 (2205 Duplex)
4	Pivot	Stainless steel 1.4021 (AISI 420)/ 1.4462 (2205 Duplex)
5	Pin	Stainless steel 1.4021 (AISI 420)/ 1.4462 (2205 Duplex)
6	Flange seal	Graphite
7	Sleeve	Stainless steel 1.4404 (AISI 316L)
8	Sleeve	Stainless steel 1.4404 (AISI 316L) nickel coated
9	Flange	Carbon steel 1.0553 (A441) zinc coated / stainless steel 1.4404 (AISI 316L)
10	Seat	Laminated stainless steel 1.4401 (AISI 316) + graphite filler
11	Seal	Graphite

Item	Name	Material
12	Cover	Carbon steel 1.0553 (A441) / stainless steel 1.4401 (AISI 316)
13	Cover seal	Graphite
14	Packing gland	Stainless steel 1.4401 (AISI 316)
15	Lock washer	Stainless steel 1.4401 (AISI 316)
16	Bracket	Carbon steel 1.0553 (A441)
17	Plate	-
18	Gland flange	Stainless steel 1.4301 (A351 CF8)
19	Packing	Graphite
20	Washer	Stainless steel 1.4401 (A4/AISI 316)
21	Hex nut	Stainless steel 1.4401 (A4/AISI 316)
22	Washer	Stainless steel 1.4401 (A4/AISI 316)
23	Bolt	Stainless steel 1.4401 (A4/AISI 316)
24	Screw	Stainless steel 1.4401 (A4/AISI 316)
25	Bolt	Stainless steel 1.4401 (A4/AISI 316)
26	Washer	Stainless steel 1.4401 (A4/AISI 316)
27	Hex nut	Stainless steel 1.4401 (A4/AISI 316)
28	Name plate	-
29	Rivet	Stainless steel 1.4401 (A4/AISI 316)
30	Stud	Stainless steel 1.4401 (A4/AISI 316)

Other materials upon request.

INSTALLATION BETWEEN FLANGES DN 80–400 (NPS 3–16) TYPE B

DN	80	100	125	150	200	250	300	350	400
NPS	3	4	5	6	8	10	12	14	16
PN 10								*	*
PN 16									
PN 25									
PN 40									
Class 150									
Class 300					x	x	x	x	x
JIS 10K					*		*	*	*
JIS 16K				*					

COATING

- Black paint Celero® Decklack 962-15, min. layer thickness 60–80 µm
- Based on customer request, different types of coating can be provided

	standard
*	suitable with additional machining
x	not available

For lug type (T) and double flanged type (F) installation, please specify in the inquiry.

ACTUATION AND TORQUES

ACTUATION POSSIBILITIES

All ABO manual gear operators, pneumatic and electric actuators can be mounted directly to ABO butterfly valves, as brackets are already installed at the factory. This allows for simple installation in the field and minimizes possible misalignment.

MANUAL GEARBOX WITH HANDWHEEL

ABO gearbox series of manual actuators combines state of art production technology, with cast iron and pressed steel construction, to provide a smooth and trouble-free operation for heavy duty on-off and throttling service of ABO valves. The rugged, cast iron body seal is weatherproof to IP67 (IP 68 is also an option). A self-locking gearing holds the valve in the desired position. Further features include a readily accessible handwheel, adjustable stop crew for closed position, removable splined drive bush with indexing facility and a facility to lock handwheel with padlock and chain. Gearboxes, as well as hand levers, can be supplemented with contacts for signalization of endpoints.

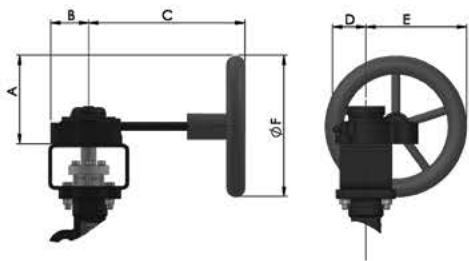

DN	80	100	125	150	200	250	300	350	400
NPS	3	4	5	6	8	10	12	14	16
A	127,5		183,5			337,5		298	448
B	47		58			72		115	
C	138		209			270,5		341	
D	47,5		62			70		110	
E	140		202,5			369		354,5	504,5
F	200		300			600		500	800
Weight	2,9		5,5			10,3		26	29
Wheel	CD200		SG300			SG600		SG500	SG800
Gearbox	242-20M		242-30M			242-40M		AB1250	

Dimensions mentioned in mm, weight in kg. Weight is approximate – total weight depends on the customer's selection of gearbox.

ACTUATORS

- **ELECTRIC ACTUATORS** – ABO series 97 electric actuators are designed for quarter turn operating application. Electric actuators of 230VAC/50Hz, 110VAC/60Hz, 3PH 380VAC/50Hz and 3PH 440VAC/60Hz can be installed on ABO butterfly valves.
- **PNEUMATIC ACTUATORS** – ABO pneumatic actuators Series 95 are rack and pinion, opposed-piston design actuators available in two versions: single acting and double acting

OPERATING TORQUES VS. WORKING PRESSURE (NM)

Opening torques (Nm)

DN	80	100	125	150	200	250	300	350	400
NPS	3	4	5	6	8	10	12	14	16
10 bar	35	65	55	110	280	283	600	1100	1600
16 bar	42	70	60	140	330	418	900	1500	2270
20 bar	57	70	71	190	370	460	1030	1900	2430
25 bar	70	85	85	210	490	656	1150	2500	3100
30 bar	85	100	97	261	530	-	-	-	-
40 bar	91	125	120	350	-	-	-	-	-
50 bar	105	150	140	-	-	-	-	-	-

Operating torques are mentioned in Nm and without safety reserve.

DN	80	100	125	150	200	250	300	350	400
NPS	3	4	5	6	8	10	12	14	16
Closing torques (water)	63	140	175	220	450	420	400	450	500
Closing torques (air)	63	140	175	220	450	565	550	1000	1300
Max. torque on shaft – 35Lx	200	343	458	635		1097	1747	2800	5078
Max. torque on shaft – 34Lx	150	257	324	476		822	1300	2300	3800

Operating torques are mentioned in Nm and without safety reserve.

WORKING CONDITIONS AND DIMENSIONS

WORKING CONDITIONS

Maximum working pressure	DN 80 - 125 (NPS 3 - 5): 50 bar (725 psi)	Working temperature range	Cast 1.0625 body: -29°C to 425°C (-20°F to 797°F)
	DN 150 (NPS 6): 40 bar (580 psi)		Cast 1.4408 body: -100°C to 500°C (-148°F to 932°F)
	DN 200 (NPS 8): 30 bar (435 psi)		Plasma cut 1.0425 body: -20°C to 425°C (-4°F to 797°F)
	DN 250 - 400 (NPS 10 - 16): 25 bar (363 psi)		Plasma cut 1.0566 body: -40°C to 425°C (-40°F to 797°F)
			Plasma cut 1.4401 body: -20°C to 425°C (-4°F to 797°F)

Maximum temperatures for each seat material are accepted only for a specific medium and limited time exposure. Please consult with our engineers for details about your application.

Pressure/temperature diagrams according to EN 12516-1 and ASME B16.34

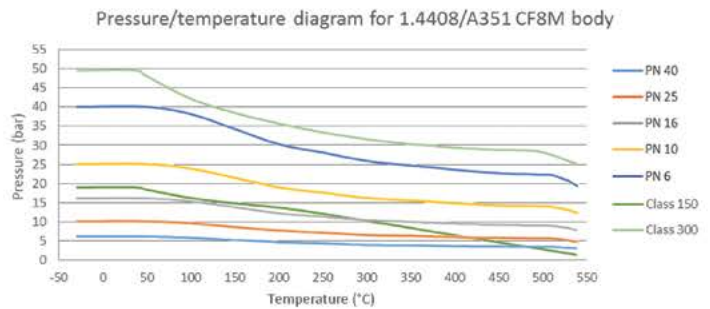
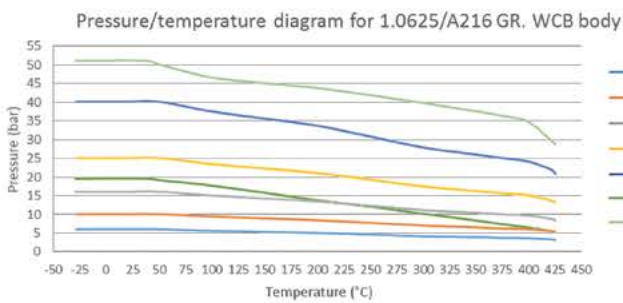

Plasma cut body

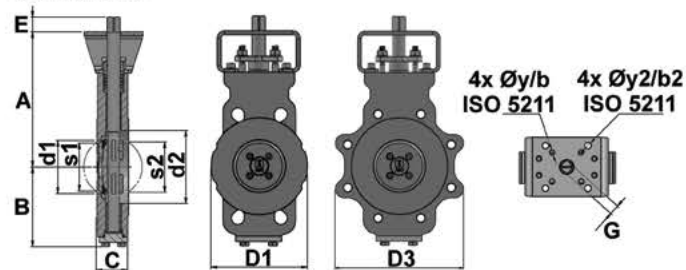

Cast body

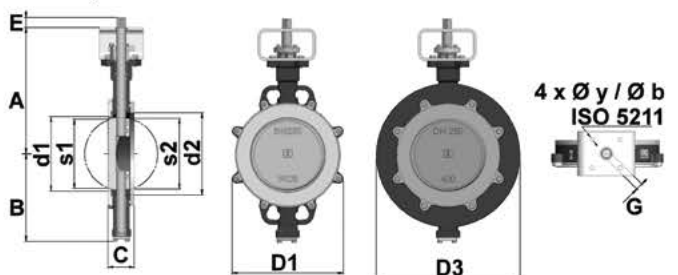

DN	NPS	d1	d2	A	B	C	D1	D3	S1	S2	E	G	ISO flange	y	b	Weight	
																B type body	T type body
80	3	77	100	173,5	119,9	47	139,5	193	61	70,8	25	14	F07	9	70	8	15
100	4	90	123,5	228,5	134,4	53	163	217,6	73	83,2	25	17	F07 / F10	9 / 11	70 / 102	12	15
125	5	110	146	148	155,2	57	193	250	96	106	25	17	F07 / F10	9 / 11	70 / 102	17	20
150	6	146	155	307	213,4	57	253	318	136	143	25	17	F10	11	102	21	30
200	8	194	204	228,5	245,8	61	305	381	185	193	25	17	F10	11	102	28	46
250	10	238	259	395	274,3	69	349	450	224	236	31	22	F12	13	125	46	70
300	12	287	309	459,5	312,8	79	393	521	270	284	31	27	F14	17	140	67	105
350	14	323	342	506	354,9	92	448	557	300	308	45	27	F16	22	165	100	148
400	16	385	405	556	401	103	542	657	342	360	58	36	F16	22	165	131	200

Dimensions mentioned in mm, weight in kg. Other dimensions upon request.

DOUBLE FLANGED TRIPLE OFFSET VALVES

GENERAL CHARACTERISTICS OF DOUBLE FLANGED TRIPLE OFFSET VALVE

ABO Series 3E double flanged high-performance butterfly valves with triple offset are designed for demanding industrial applications. Thanks to their design, ABO series 3E double flanged butterfly valves provide excellent performance in applications such as transport of steam, chilled water, gasoline, jet fuel, oil, gas, pulp and paper. The sophisticated triple offset system eliminates friction in the seat area when opening and closing the valve, minimizing wear of the sealing elements, and significantly prolonging the service life of the valve. The seat is machined into an oblique truncated conical shape directly defining the correct alignment of the disc. Its geometry naturally prevents its movement beyond the safe limit. The seat surface is provided with a weld / thermal spray coating of Stellite®, which ensures its long-term tightness and minimal maintenance cost due to its hardness and wear resistance characteristics. The sealing elements are made only of metallic materials and graphite filler in order to withstand long-term exposure to high temperatures (up to 500 °C). ABO series 3E butterfly valves have been designed with the maximal respect to the simplicity of repairs and maintenance. Therefore, it is possible to replace the laminated seat ring in the disc and seat surface in the body by simply unscrewing the bolts and dismounting the flange rings that are holding them (interchangeable part with Stellite® thermal sprayed seat surface available from DN 150 and above). The double flanged version of ABO triple offset valves is available in DN 80, 100, 125, 150 and 200.

TRIPLE OFFSET

Triple offset design ensures safe function and tightness even in case of changing temperatures, or in case of pressure peak. It also eliminates friction in the seat area when opening and closing the valve, minimizing wear of the sealing elements, and significantly prolonging the service life of the valve. The first offset shifts the axis of the shaft rotation off the plane that lies on the pipeline axis. The second offset moves the center plane of the closing element parallel to its flat surface outside of the axis of its rotation. The third offset deflects the axis of rotational symmetry of the seat surface outside of the axis perpendicular to the flat surface of the disc, running through its center. A set of all these offsets results in specific valve properties such as friction elimination during opening/closing cycle and ideal contact of the disc and seat in closed position. Further, its sophisticated geometry naturally prevents the obturator from moving beyond the safe limit and directly defines the correct alignment of sealing elements.

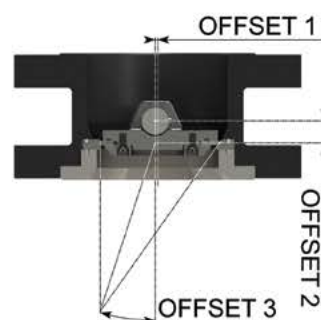

DRAWING AND MATERIALS

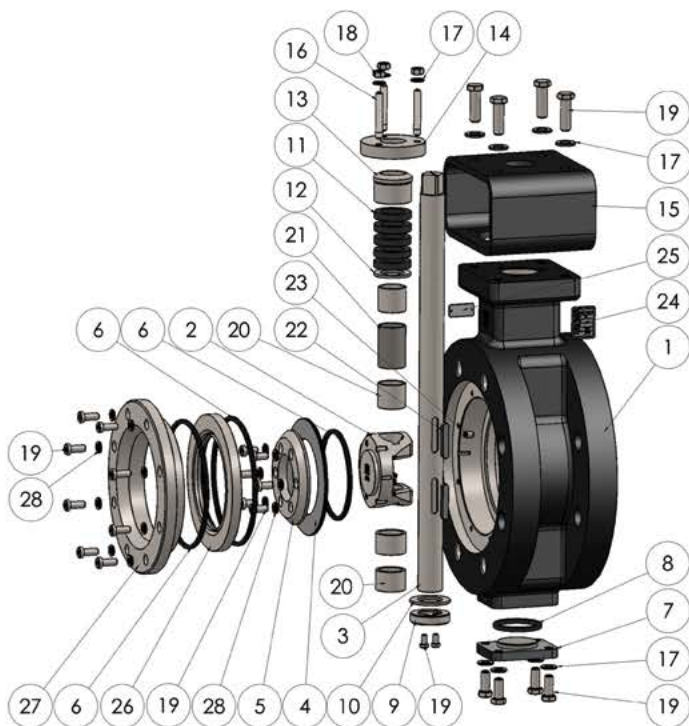

Item	Name	Material
1	Body	5 – Carbon steel 1.0625 (A216 WCB)
		4 – Stainless steel 1.4408 (A351 CF8M)
2	Disc	5 – Carbon steel 1.0625 (A216 WCB) nickel plated
		4 – Stainless steel 1.4401 (AISI 316), 1.4408 (A351 CF8M)
3	Shaft	Stainless steel 1.4021 (AISI 420), 1.4462 (2205 Duplex)
4	Seal ring (laminated)	Stainless steel 1.4401 (AISI 316) + graphite filler
5	Retainer flange	Stainless steel 1.4301 (AISI 304)
6	Spiral gasket (laminated)	Stainless steel 1.4541 (AISI 321) + graphite filler
7	Cover	Carbon steel 1.0553 (ASTM A441), stainless steel 1.4401 (AISI 316)
8	Cover seal	Stainless steel 1.4541 (AISI 321) + graphite filler
9	Bottom	Stainless steel 1.4401 (AISI 316)
10	Spacer ring	Stainless steel 1.4401 (AISI 316)
11	Packing	Graphite
12	Packing ring	Stainless steel 1.4404 (AISI 316L)
13	Packing gland	Stainless steel 1.4401 (AISI 316)
14	Gland flange	Stainless steel 1.4301 (AISI 304)
15	Bracket	Carbon steel 1.0553 (ASTM A441)
16	Stud	Stainless steel 1.4401 (A4/AISI 316)
17	Washer	Stainless steel 1.4401 (A4/AISI 316)
18	Hex nut	Stainless steel 1.4401 (A4/AISI 316)
19	Bolt	Stainless steel 1.4401 (A4/AISI 316)
20	Sleeve	Stainless steel 1.4404 (AISI 316L) nickel coated
21	Sleeve	Stainless steel 1.4404 (AISI 316L)
22	Disc key	Stainless steel 1.4401 (A4/AISI 316), 1.0060 (ASTM 6150)
23	Retaining screw	Stainless steel 1.4401 (A4/AISI 316)
24	Name plate	Stainless steel
25	Delta plate	Stainless steel
26	Seat	Duplex stainless steel 1.4462 (AISI 318 LN) stellite contact surface
27	Flange ring	Carbon steel 1.0553 (ASTM A441)
28	Wedge lock washer	Stainless steel 1.4401 (A4/AISI 316)

Other materials upon request.

COATING

- Black paint Celerol® Decklack 962-15, min. layer thickness 60–80 µm
- Based on customer request, different types of coating can be provided

DESIGN BENEFITS OF DOUBLE FLANGED TRIPLE OFFSET VALVES

STEM SEALING SYSTEM

Stem sealing system consists of a series of soft graphite sealing rings preventing leakage around the shaft. Graphite is a material which perfectly seals and resists high temperatures. Optimization of the ratio between tightness around the shaft and the actuating torque can be easily achieved by tightening or loosening the nuts holding the packing flange.

SHAFT BEARINGS

Durable slide bearings center the shaft in the body and define its precise location, thereby minimizing unwanted backlash and ensuring proper alignment of the sealing ring on the seat surface.

SEAT FLANGE RING

A flange ring holds the interchangeable seat in the body in its place. Removal of the flange allows for an easy maintenance and repairs of seat surface (available from DN 150 and above).

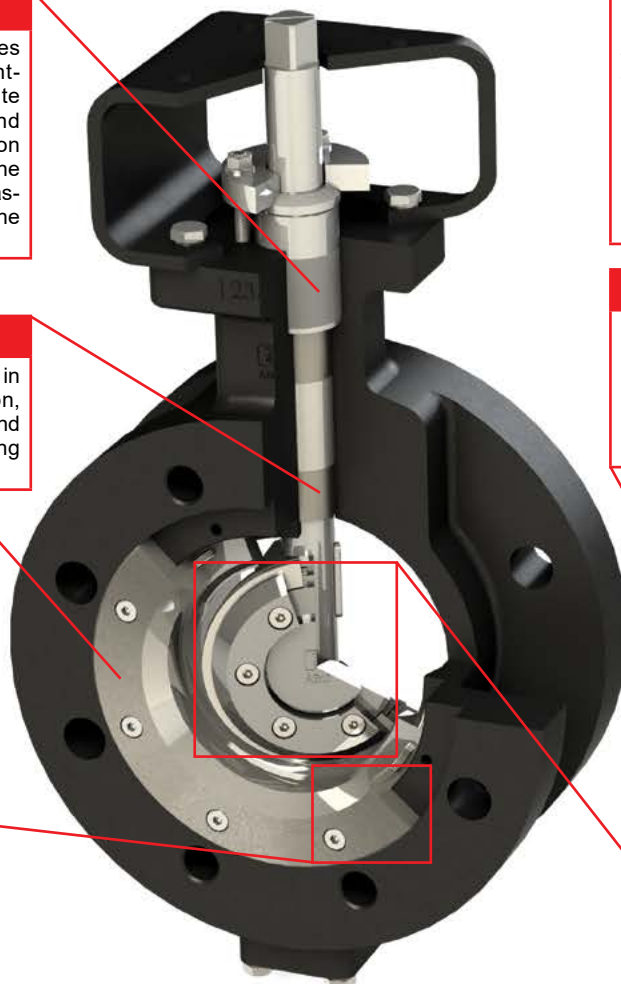

LAMINATED SEALING RING

The sealing ring is formed by a sandwich of stainless steel sheets layered with soft filler of graphite. This composition is able to withstand high temperatures and ensures excellent resilience of the sealing element even during significant fluctuations of medium temperature and pressure. In case of damage or wear, the laminated sealing ring can be easily replaced by removing the flange that holds it in place.

DISC FLANGE RING

The flange ring that provides the alignment of the laminated sealing ring in the disc, combined with the spiral seal, ensures perfect tightness. Thanks to this design, the laminated sealing ring can be easily replaced at any time.

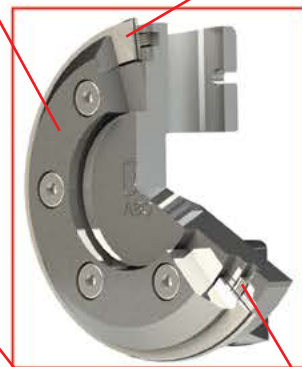

INTERCHANGEABLE SEAT

The seat coated with Stellite® is inserted into the body as a separate part (available from DN 150 and above), which can be easily replaced in case of wear or damage. This design simplifies maintenance and significantly reduces the cost of repairs.

SPIRAL GASKET

Spirally wound stainless steel band with a soft graphite filler guarantees a perfect seal, even under the circumstance of large fluctuations of temperature and pressure inside the pipe.



EUROPEAN UNION
European Regional Development Fund
Operational Programme Enterprise
and Innovations for Competitiveness

All statements, technical information in this brochure are tentative and for general use only and do not constitute a recommendation or guarantee for any specific service or application requirement. Consult ABO representative or factory for specific requirements and material selection for your intended application. The right to change or modify product design or product without prior notice is reserved. ABO valve accepts no liability for damages caused by bad interpretation or use of the information included in this brochure.

1. 10. 2017

Data subject to change.

Company HQ – Czech Republic:
ABO valve, s.r.o.
Dalimilova 285/54, 783 35 Olomouc
Tel.: +420 585 224 087
Email: export@abovalve.com
www.abovalve.com

USA:
ABO Controls, LLC
Houston, Texas
Tel.: +1 (832) 291-9600
Email: salesUSA@abovalve.com
www.abocontrols.com

Singapore:
ABO Valve Pte. Ltd.
Singapore
Tel.: +65 9169 4562
Email: lsw@abovalve.com
www.abovalve.com

Slovakia:
ABO Slovakia s.r.o.
Banská Bystrica
Tel.: +421 484 145 633
Email: aboslovakia@aboslovakia.sk
www.aboslovakia.sk

Bahrain:
ABO Middle East
Manama
Tel.: +973-3444 9065
Email: jimnichien@abovalve.com
www.abovalve.com

United Arab Emirates:
ABO UAE
Abu Dhabi
Tel.: +971 56 9207964
Email: bharti@abovalve.com
www.abovalve.com

Germany:
ABO Armaturen GmbH
Mönchengladbach
Tel.: +49 162 417 45 47
Email: d.beckers@abovalve.com
www.abo-armaturen.de

Russia:
ABO ARMATURA Ltd.
Smolensk
Tel.: +7(4812) 240 020
Email: aboarmatura@yandex.ru
www.aboarmatura.ru

Brazil:
ABO do Brasil Válvulas Industriais Eireli
Valinhos
Tel.: sales@abovalve.com
www.abovalve.com

Ukraine:
ABO Ukraine LLC
Dnipro
Tel.: +38 056 733 95 70
Email: a.marushchak@abovalve.com
www.abovalve.com.ua

Turkey:
ABO Armaturen LTD STI
Istanbul
Tel.: +90-216 527 36 34
Email: m.sahin@abovalve.com
www.abovalve.com

China:
ABO Flow Control
Shanghai
Tel.: +86 13601522831
Email: wen@abovalve.com
www.abovalve.com