



**ABO** valve

GET IN CONTROL  
INTELLIGENT • INNOVATIVE • INTERNATIONAL  
STAY IN CONTROL

# FLUOROPOLYMER-LINED VALVES



[www.abovalve.com](http://www.abovalve.com)

## LINED BALL VALVE

Lined ball valves are ideally suited for corrosive applications, requiring reliable performance, tight shutoff, and constant torque. The valves successfully handle a multitude of corrosive applications in industries such as chemical, petrochemical, pharmaceutical, pulp and paper, foundries and mining like sulphuric acid, etc.

### DESIGN

API 608, DIN 3357, JIS B2071

### SIZES

DN50 to DN300 (Other sizes are available on request)

### WORKING PRESSURE AND TEMPERATURE

Pressure: 6-10-16 Bar

Temperature: From -20°C /200°C

### CONNECTION

DIN PN10, PN16

ASME B16.5 -class 150

### TESTING

API 598, DIN 12569

### SPARK TEST

14 Kv

### OPERATION TYPE

Lever, Gear, Pneumatic, Electric Act

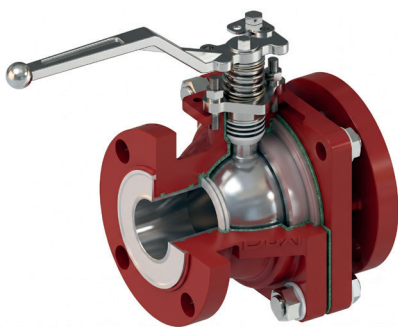
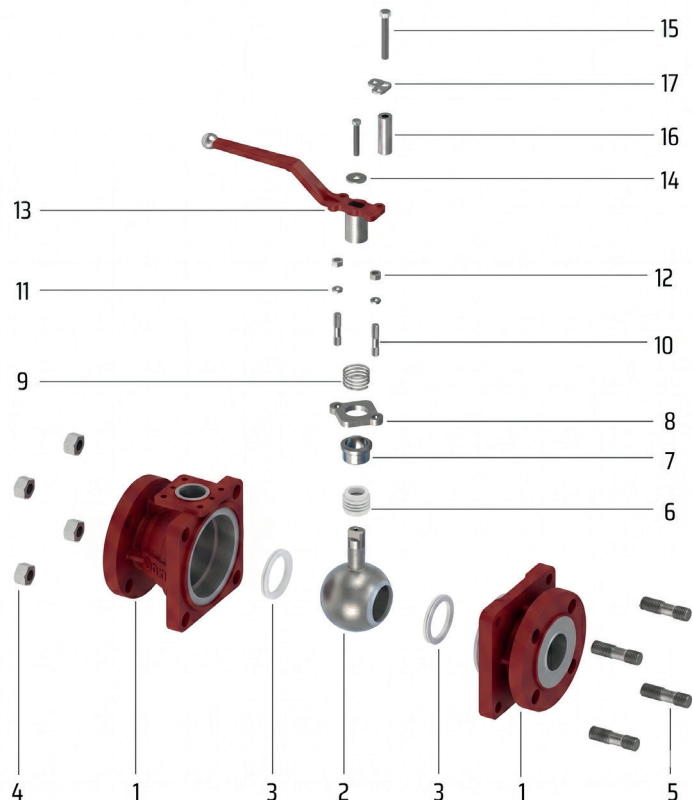

#### Standart part list

Part No	Part Name	Part Material
1	Body	WCB /CF8M/GGG40 With PTFE or PFA or ETFE or FEP Lined
2	Ball	WCB /CF8M/GGG40 With PTFE or PFA or ETFE or FEP Lined
3	Seat Ring	PTFE
4	Bolt	Stainless Steel
5	Nut	Stainless Steel
6	Packing	PTFE
7	Shaft Sleeve	Stainless Steel
8	Gland	Stainless Steel
9	Spring	Stainless Steel
10	Stud Bolt	Stainless Steel
11	Washer	Stainless Steel
12	Nut	Stainless Steel
13	Handle	Stainless Steel
14	Washer	Stainless Steel
15	Bolt	Stainless Steel
16	Lever Stop	Stainless Steel
17	Locker	Stainless Steel

**DIMENSION**

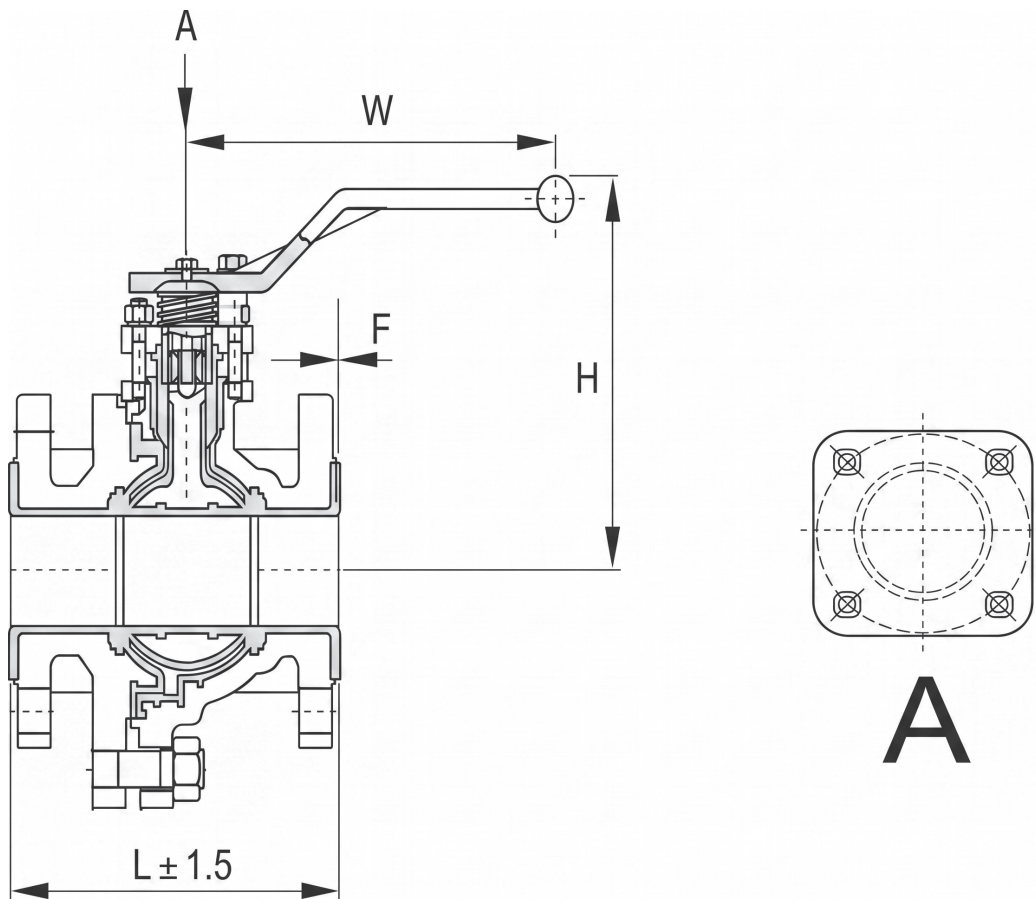

DN	CLASS 150			PN10/16			A	TORQUE
	L	H	W	L	H	W		
15	108	126	160	130	126	160	F05	10
20	117	126	160	150	126	160	F05	10
25	127	131	160	160	131	160	F05	10
32	140	131	160	180	131	160	F05	22
40	165	160	200	200	160	200	F07	22
50	179	170	200	230	170	200	F07	30
65	190	170	200	290	170	200	F07	30
80	203	230	260	310	230	260	F07	70
100	229	265	313	350	265	313	F10	95
125	265	265	313	400	265	313	F10	95
150	267	347	535	480	347	535	F12	147
200	292	NOT LEVER	NOT LEVER	600	NOT LEVER	NOT LEVER	F14	365
250	533	NOT LEVER	NOT LEVER	730	NOT LEVER	NOT LEVER	F14	460
300	610	NOT LEVER	NOT LEVER	850	NOT LEVER	NOT LEVER	F16	495

## LINED DIAPHRAGM VALVE

Weir Type diaphragm valves feature a rugged design that incorporates the most advanced, field-proven materials, ensuring reliable and efficient operation over an extended service life. The heavy-duty construction provides superior resistance to demanding process conditions. This valve design minimizes diaphragm travel, resulting in reduced wear, extended service life, and precise flow control, even in the most severe operating environments. A wide range of options is available for body materials, body linings, types of operation, and end connections, making these valves suitable for most industrial applications. Stringent quality standards are strictly maintained throughout the entire manufacturing process, including material selection, casting, machining, assembly, inspection, and finishing, regardless of valve size or configuration.

### DESIGN

MSP SP88

### SIZES

DN50 to DN300 (Other sizes are available on request)

### WORKING PRESSURE AND TEMPERATURE

Pressure: 6-10-16 Bar

Temperature: From -20 °C / 200 °C

### CONNECTION

DIN PN10, PN16

ASME B16.5 -class 150

### TESTING

API 598, DIN 12569

### SPARK TEST

14 Kv

### OPERATION TYPE

Lever, Gear, Pneumatic, Electric Act

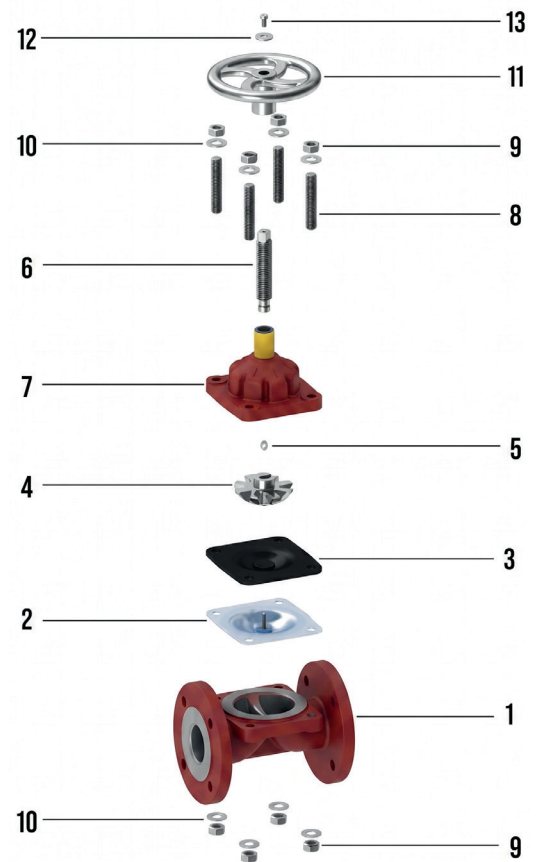

#### Standart part list

Part No	Part Name	Part Material
1	Body	WCB /CF8M/GGG40 With PTFE or PFA or ETFE or FEP Lined
2	Diaphragm	PFA OR PTFE
3	Rubber	Viton
4	Compressor	Carbon Steel
5	Block	Stainless Steel
6	Spindle	PTFE
7	Bonnet	WCB /CF8M/GGG40
8	Bolt	Stainless Steel
9	Nut	Stainless Steel
10	Washer	Stainless Steel
11	Handwheel	Stainless Steel
12	Washer	Stainless Steel
13	Bolt	Stainless Steel



**DIMENSION**

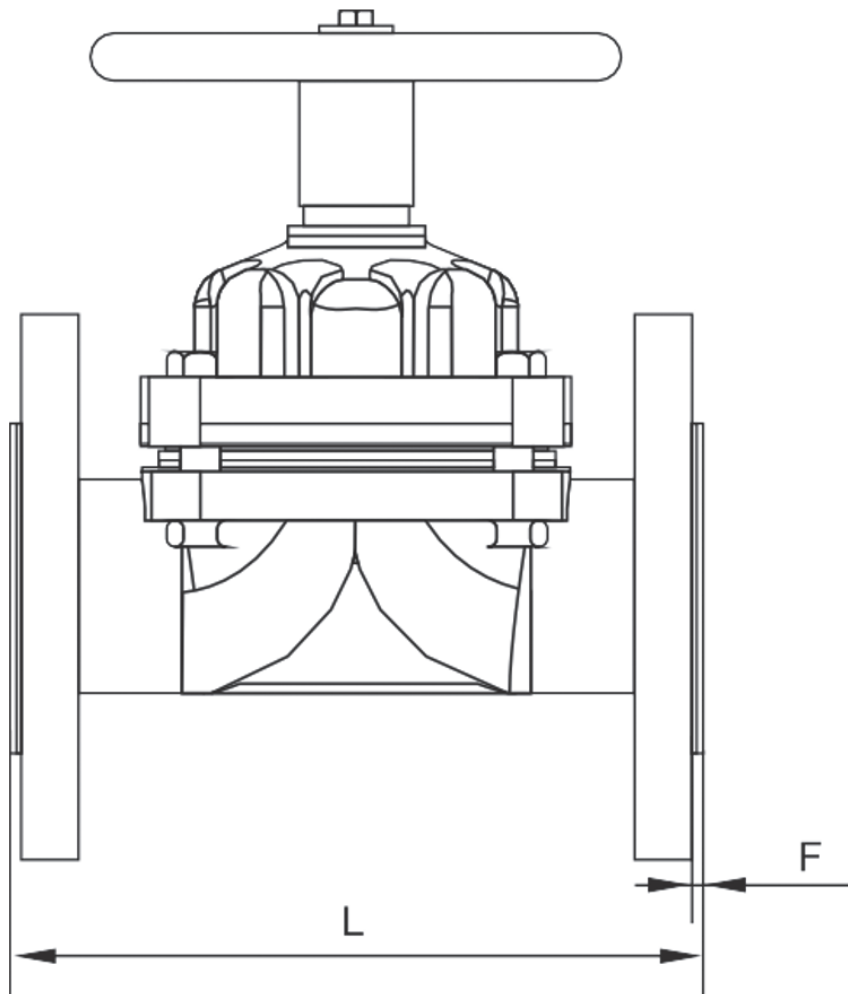

SIZE	ASME B 16.5		DIN2532 PN10		BS 5156	
DN	L	F	L	F	L	F
15	108	3	130	3	108	3
20	146	3	150	3	117	3
25	146	3	160	3	127	3
32	159	3	180	3	146	3
40	175	3	200	3	159	3
50	200	3	230	3	190	3
65	226	3	290	3	216	3
80	260	4	310	4	254	4
100	327	4	350	4	305	4
125	400	4	400	4	356	4
150	480	4	480	4	406	4
200	600	4	600	4	521	4
250	730	4	730	4	635	4
300	850	5	850	5	749	5

## LINED PLUG VALVE

Our lined plug valves are engineered to deliver unobstructed flow in the fully open position, thereby minimizing pressure drop and optimizing flow efficiency. They also provide stable, accurate, and reliable performance under throttling and modulating service conditions. The integrally molded internal lining ensures superior chemical resistance, significantly enhancing durability and extending service life. Our products are manufactured in accordance with state-of-the-art production technologies, supported by rigorous and continuous quality control throughout all stages of manufacturing—from raw material selection and processing to final assembly, inspection, and testing, ensuring full compliance with the highest international quality standards.

### DESIGN

API 599

### SIZES

DN50 to DN300 (Other sizes are available on request)

### WORKING PRESSURE AND TEMPERATURE

Pressure: 6-10-16 Bar

Temperature: From -20 °C / 200 °C

### CONNECTION

DIN PN10, PN16

ASME B16.5 -class 150

### TESTING

API 598, DIN 12569

### SPARK TEST

14 Kv

### OPERATION TYPE

Lever, Gear, Pneumatic, Electric Act

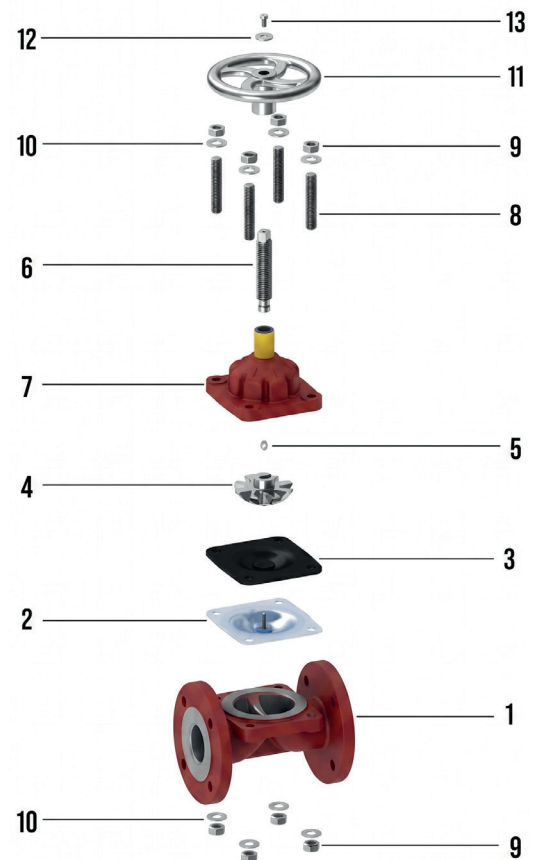

#### Standart part list

Part No	Part Name	Part Material
1	Body	WCB /CF8M/GGG40 With PTFE or PFA or ETFE or FEP Lined
2	Plug	WCB /CF8M/GGG40 With PTFE or PFA or ETFE or FEP Lined
3	O ring	Viton
4	Diaphragm	PTFE
5	Gasket	Stainless Steel
6	Bonnet	WCB /CF8M/GGG40
7	Washer	Stainless Steel
8	Bolt	Stainless Steel
9	Handle	Stainless Steel
10	Washer	Stainless Steel
11	Bolt	Stainless Steel
12	Screw	Stainless Steel

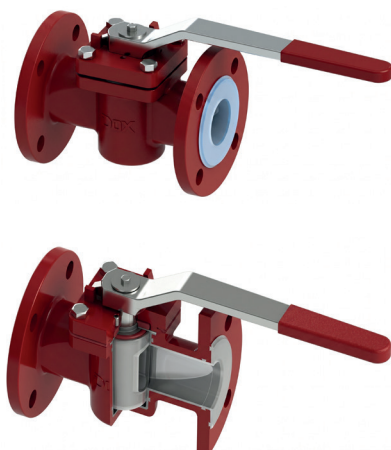

**DIMENSION**

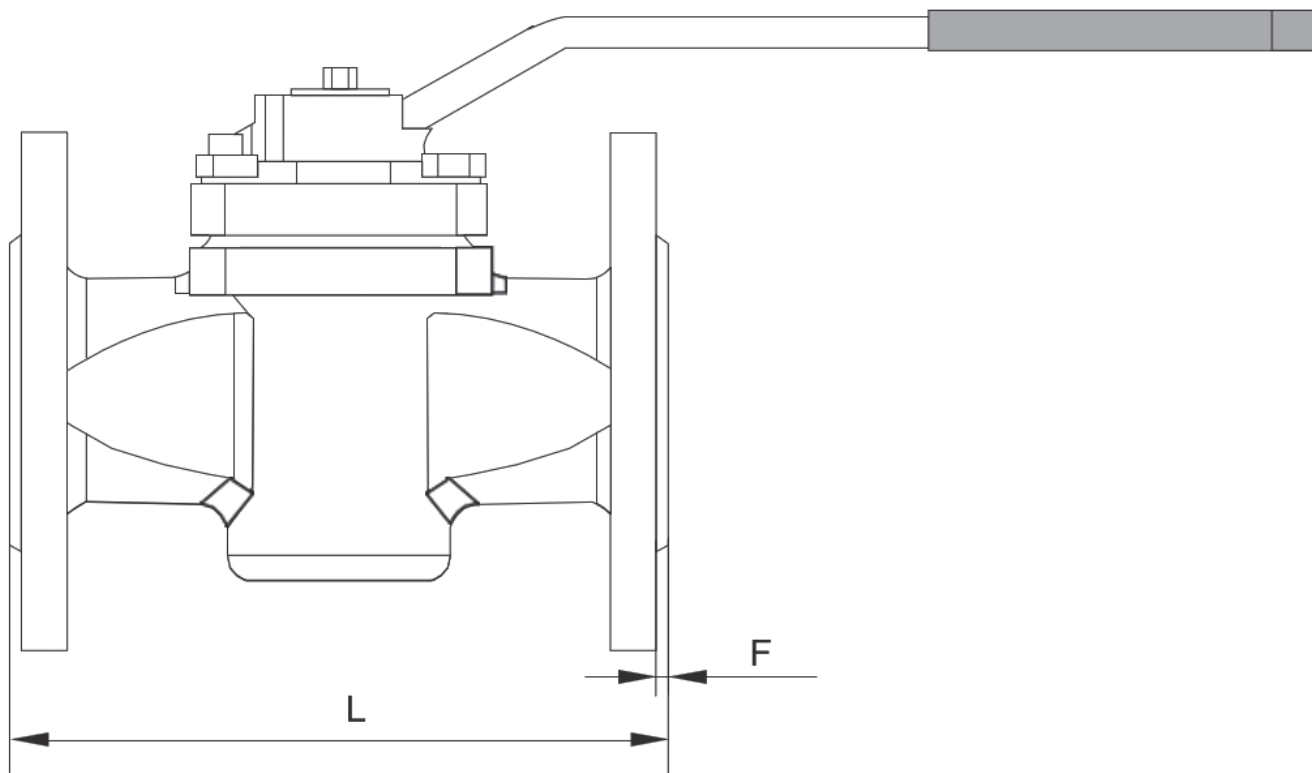

SIZE	ASME B 16.5		DIN2532 PN10		JIS 10K	
	DN	L	F	L	F	L
15	108	3	130	3	130	3
20	117	3	150	3	150	3
25	127	3	160	3	160	3
40	165	3	200	3	200	3
50	179	3	230	3	230	3
80	203	3	310	3	310	3
100	229	4	350	4	350	4
150	267	4	480	4	480	4
200	292	4	600	4	600	4
250	330	5	730	5	730	5
300	356	5	850	5	850	5

## LINED FLANGED CHECK VALVE

Our ball check valves are specifically engineered for service in fluid systems handling corrosive media and are lined with PFA to provide exceptional chemical resistance. The valves are suitable for both horizontal and vertical installations, offering flexibility across a wide range of industrial applications. The valve body is manufactured from a robust combination of ductile iron and steel, ensuring high mechanical strength, structural integrity, and reliable long-term performance under demanding operating conditions.

### DESIGN

API 594

### SIZES

DN15 to DN200 (Other sizes are available on request)

### WORKING PRESSURE AND TEMPERATURE

Pressure: 6-10-16 Bar

Temperature: From -20°C / 200°C

### CONNECTION

DIN PN10, PN16

ASME B16.5 -class 150

### TESTING

API 598, DIN 12569

### SPARK TEST

14 Kv

### OPERATION TYPE

NO OPERATION

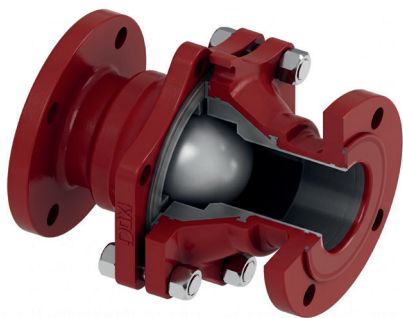
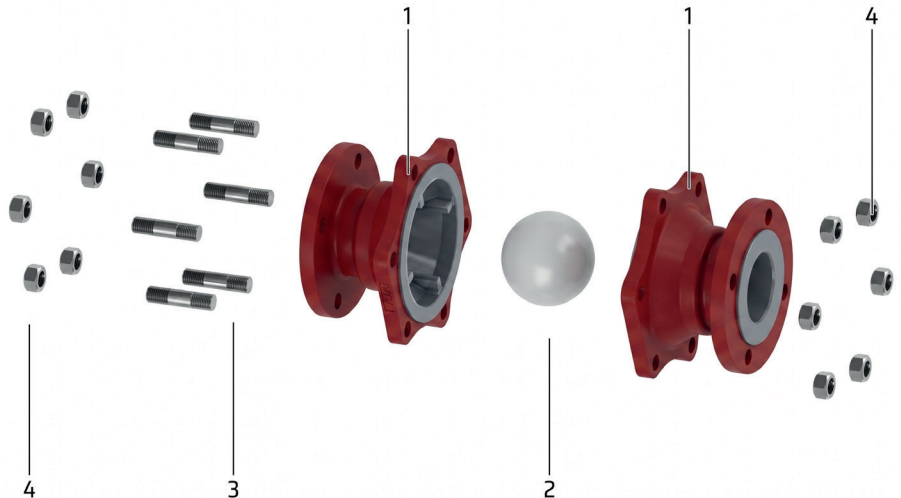
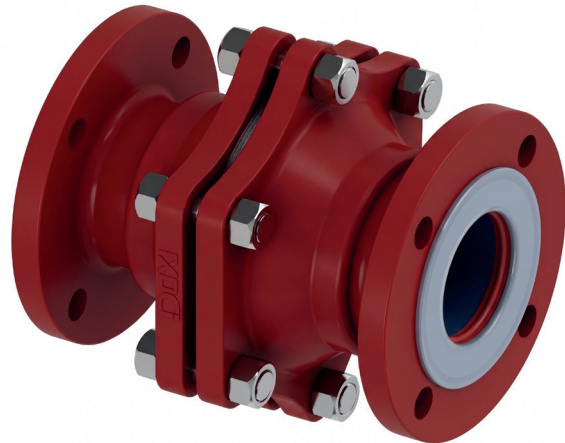

#### Standart part list

Part No	Part Name	Part Material
1	Body	WCB /CF8M/GGG40 With PTFE or PFA or ETFE or FEP Lined
2	Ball	WCB /CF8M/GGG40 With PTFE or PFA or ETFE or FEP Lined
3	O ring	Viton
4	Diaphragm	PTFE
5	Gasket	Stainless Steel
6	Bonnet	WCB /CF8M/GGG40
7	Washer	Stainless Steel
8	Bolt	Stainless Steel
9	Handle	Stainless Steel
10	Washer	Stainless Steel
11	Bolt	Stainless Steel
12	Screw	Stainless Steel

**DIMENSION**

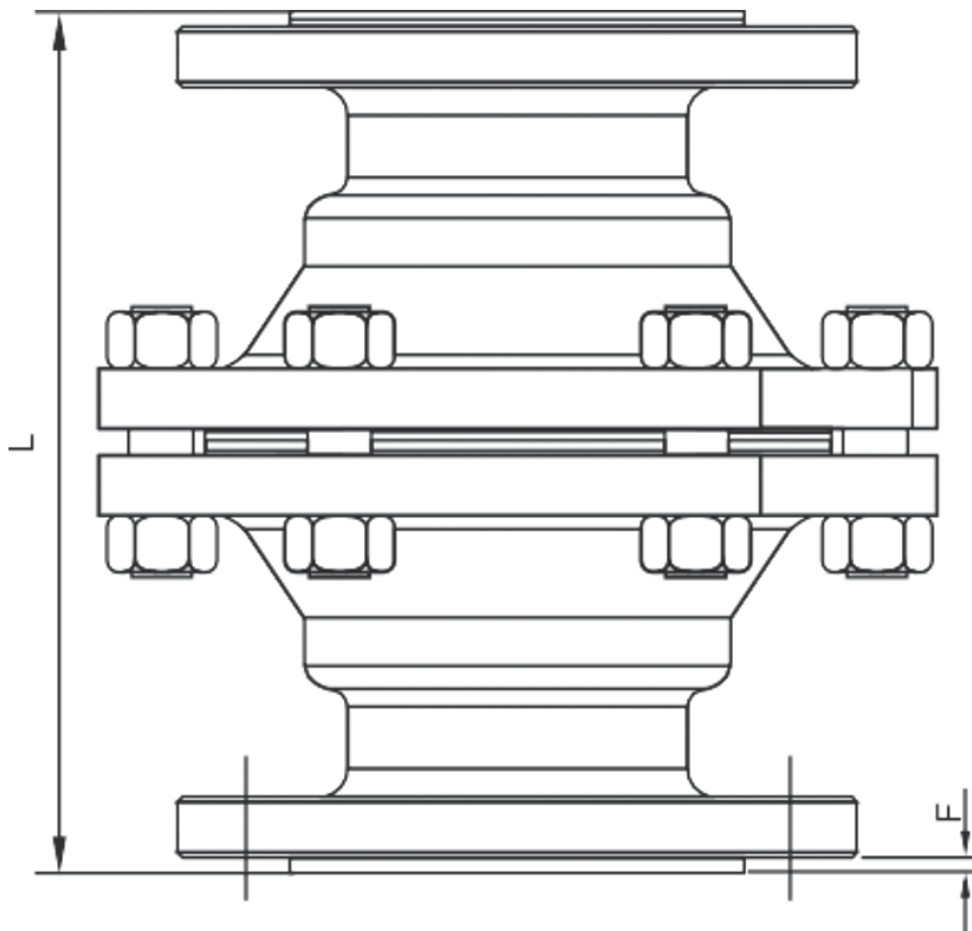

SIZE	ASME B 16.5		DIN2532 PN10		JIS 10K	
DN	L	F	L	F	L	F
15	140	3	140	3	140	3
20	140	3	140	3	140	3
25	140	3	140	3	140	3
40	178	3	178	3	178	3
50	203	4	203	4	203	4
80	241	4	241	4	241	4
100	292	4	292	4	292	4
150	356	4	356	4	356	4
200	360	4	360	4	360	4

## LINED WAFER CHECK VALVE

Fluoropolymer-lined swing check valves are engineered for reliable operation in severely corrosive service conditions, providing outstanding chemical compatibility across a wide range of aggressive media. The advanced hinge pin geometry enables the valve disc to achieve a secure and consistent seal independent of line pressure, allowing dependable performance in both horizontal and vertical mounting orientations. The two-piece valve construction is designed to enhance sealing integrity by eliminating potential leakage paths. An integrally molded seat surface within the body liner provides precise alignment and tight shut-off against the disc when in the closed position, ensuring long-term operational reliability and reduced maintenance requirements.

### DESIGN

API 594

### SIZES

DN15 to DN600 (Other sizes are available on request)

### WORKING PRESSURE AND TEMPERATURE

Pressure: 6-10-16 Bar

Temperature: From -20°C / 200°C

### CONNECTION

DIN PN10, PN16

ASME B16.5 -class 150

### TESTING

API 598, DIN 12569

### SPARK TEST

14 Kv

### OPERATION TYPE

NO OPERATION

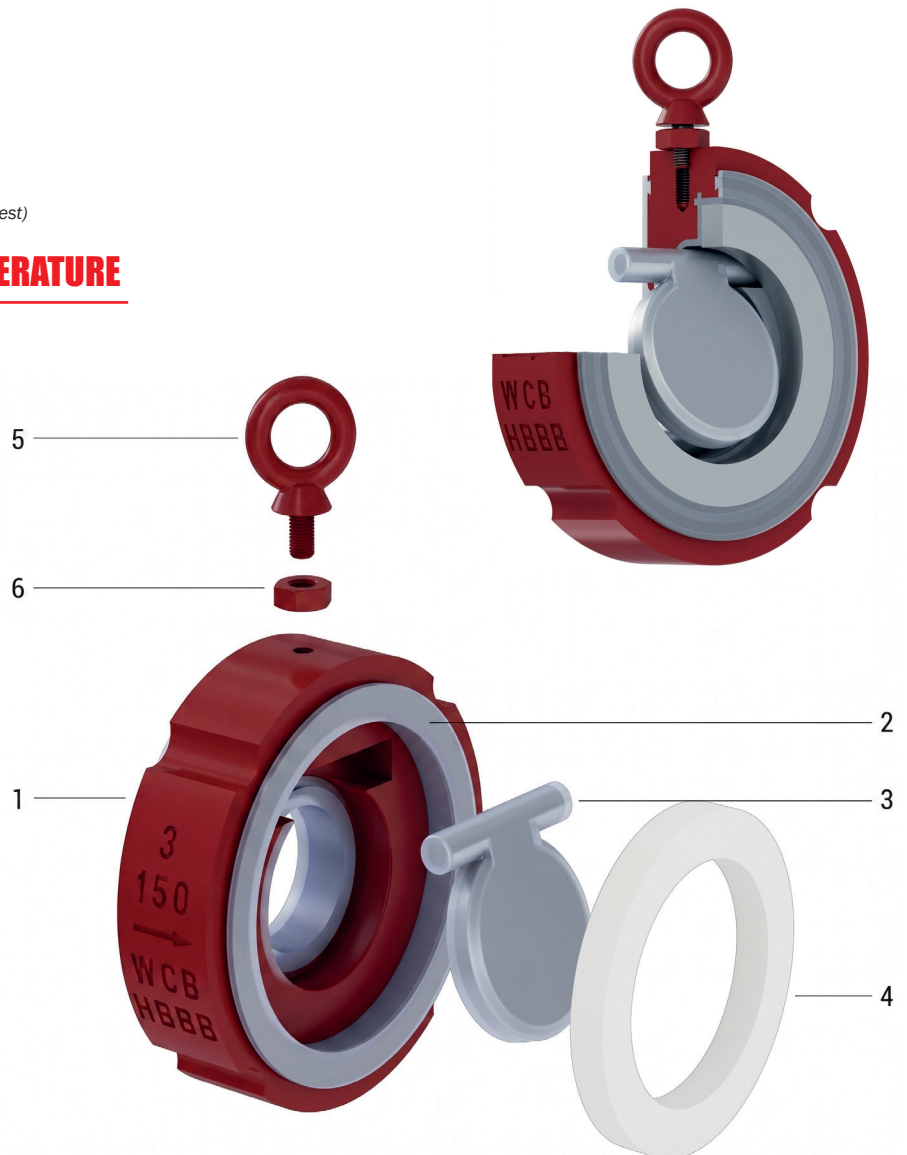
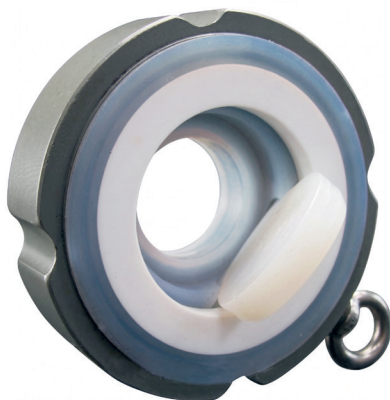

#### Standart part list

Part No	Part Name	Part Material
1	Body	WCB /CF8M/GGG40 With PTFE or PFA or ETFE or FEP Lined
2	Body Lined	PTFE or PFA or ETFE or FEP Lined
3	Disc	WCB /CF8M/GGG40 With PTFE or PFA or ETFE or FEP Lined
4	Retainer Ring	PTFE or PFA or ETFE or FEP Lined
5	Hand Ring	WCB or CF8M
6	Nut	WCB or CF8M

**DIMENSION**

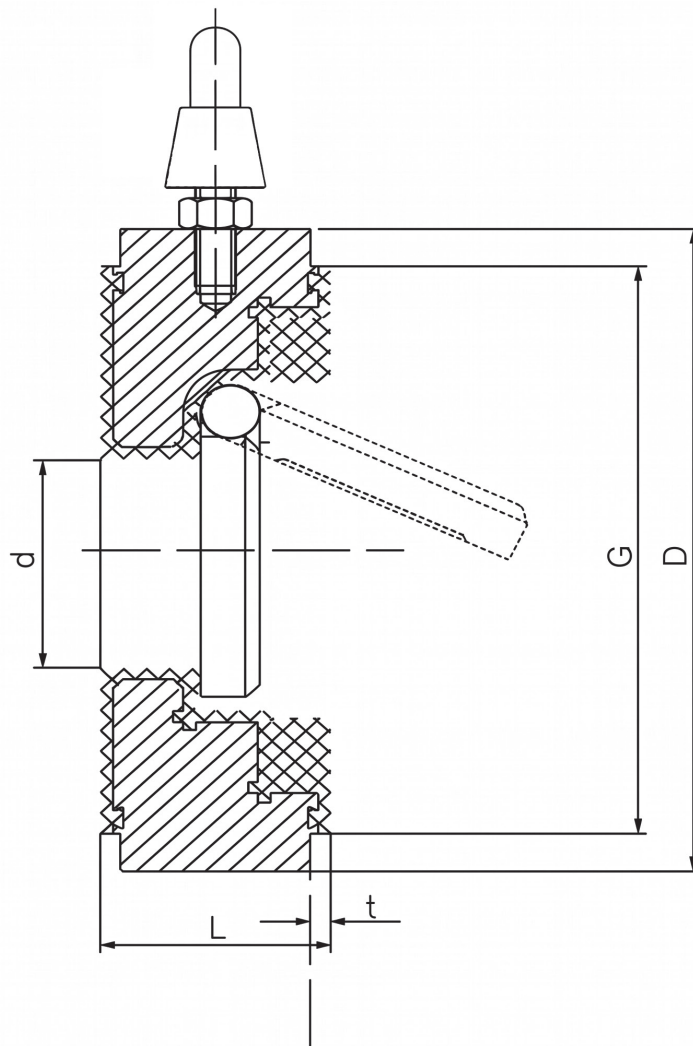

SIZE	ASME B 16.5		DIN2532 PN10		JIS 10K
DN	L	d	G	D	t
50	43	30	92	112	3,5
65	46	55	104	131	3,5
80	46	55	127	143	3,5
100	52	72	157	181	3,5
150	56	115	215	231	3,5
200	60	155	269	288	3,5
250	68	190	323	350	4
300	78	240	381	419	4
350	92	275	412	462	4
400	102	305	469	526	4,5
450	114	355	533	562	4,5
500	127	405	584	619	4,5
600	154	450	692	732	4,5

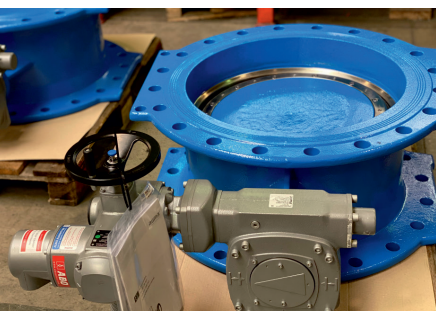
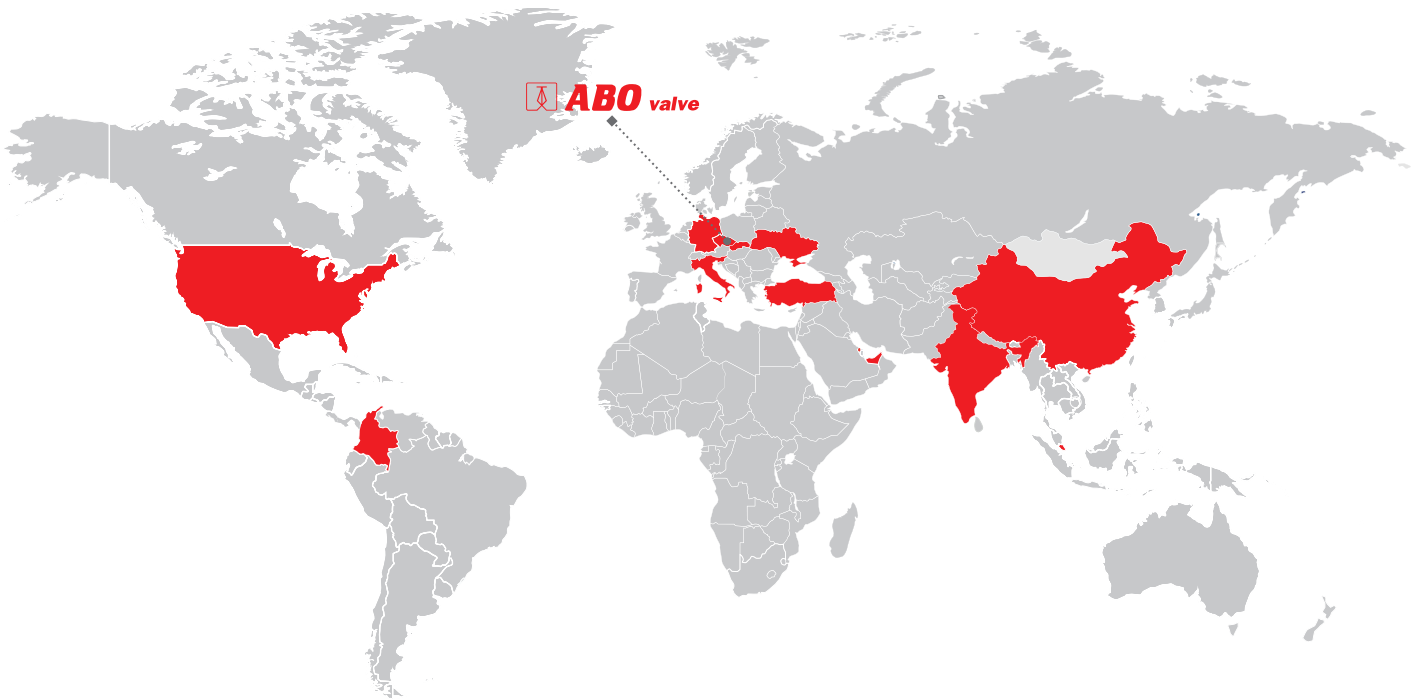

### Czech Republic

**ABO valve, s.r.o.**  
Dalimililova 285/54  
783 35 Olomouc  
tel.: +420 585 223 955  
sales@abovalve.com

### Ukraine

**ABO Ukraine LLC**  
Dnipro  
tel.: +38 056 733 95 70  
sales.ua@abovalve.com

### Singapore

**ABO Valve Pte. Ltd.**  
Singapore  
+65 6254 0861  
sales.sg@abovalve.com

### UAE

**Sales representatives**  
Abu Dhabi  
tel.: +971 56 920 7964  
sales.ae@abovalve.com



### Slovakia

**ABO Slovakia, s.r.o.**  
Nové Mesto nad Váhom  
tel.: +421 947 902 862  
sales.sk@abovalve.com

### Turkey

**ABO Armaturen LTD STI**  
Istanbul  
tel.: +90 0543 321 54 09  
sales.tr@abovalve.com

### USA

**ABO Controls, LLC**  
Houston  
tel.: +1 832 497 5303  
sales.us@abovalve.com

### Latin America

**Sales representation**  
Cali, Colombia  
+57 316 381 8343  
sales.la@abovalve.com

Follow us:



[www.abovalve.com](http://www.abovalve.com)

### Germany

**ABO Armaturen GmbH**  
Essen  
tel.: +49 (0) 152 / 26229501  
sales.de@abovalve.com

### China

**ABO Flow Control**  
Shanghai  
tel.: +86 136 015 228 31  
sales.cn@abovalve.com

### Bahrain

**Sales representatives**  
Manama  
tel.: +973 - 3444 9065  
sales.gulf@abovalve.com

### Italy

**ABO valve Italiana S.r.l.**  
Agrate Brianza  
tel.: +39 334 9102143  
sales.it@abovalve.com

### India

**ABO Controls Pvt. Ltd.**  
Pune  
tel.: +91 773 820 4779  
sales.in@abovalve.com

*The technical information described in this leaflet is tentative and for general use only and does not constitute a recommendation or guarantee for any specific service or application requirement. Please consult ABO representative or factory for specific requirements and material selection for your intended application. The right to change or modify product design or product without prior notice is reserved. ABO valve accepts no liability for damages caused by bad interpretation or use of the information included in this brochure.*

