

ABO valve

Engineered for life

CONCENTRIC BUTTERFLY VALVES

Body design

Interflanged

WAFER type with through holes

Double flanged

LUG type with threaded holes

With through / threaded holes

Nominal size

Interflanged

DN32 - DN600

Double flanged

DN700 - DN1600 (Series 20)

DN50 - DN2200 (Series 13)

Working pressure

6 bar / 10 bar / 16 bar

Flange connection

PN6/PN10/PN16/Class 150

Working temperature

-40°C / +150°C

Working media

Potable water
Waste water
Hot industrial water
Heating water
Sea water
Chemicals
Gas / Oil and gas
Oil / Oil derivatives
Loose materials
Air
Beverages / Food
Malt
Sugar juice

Tightness

Class A

Features

Concentric design Bidirectional valve

Body with safety plug (up to DN400)
Body with pin cover (DN450-DN600)
Demountable valve
Easy service

SERIES 900

industrial line

www.abovalve.com

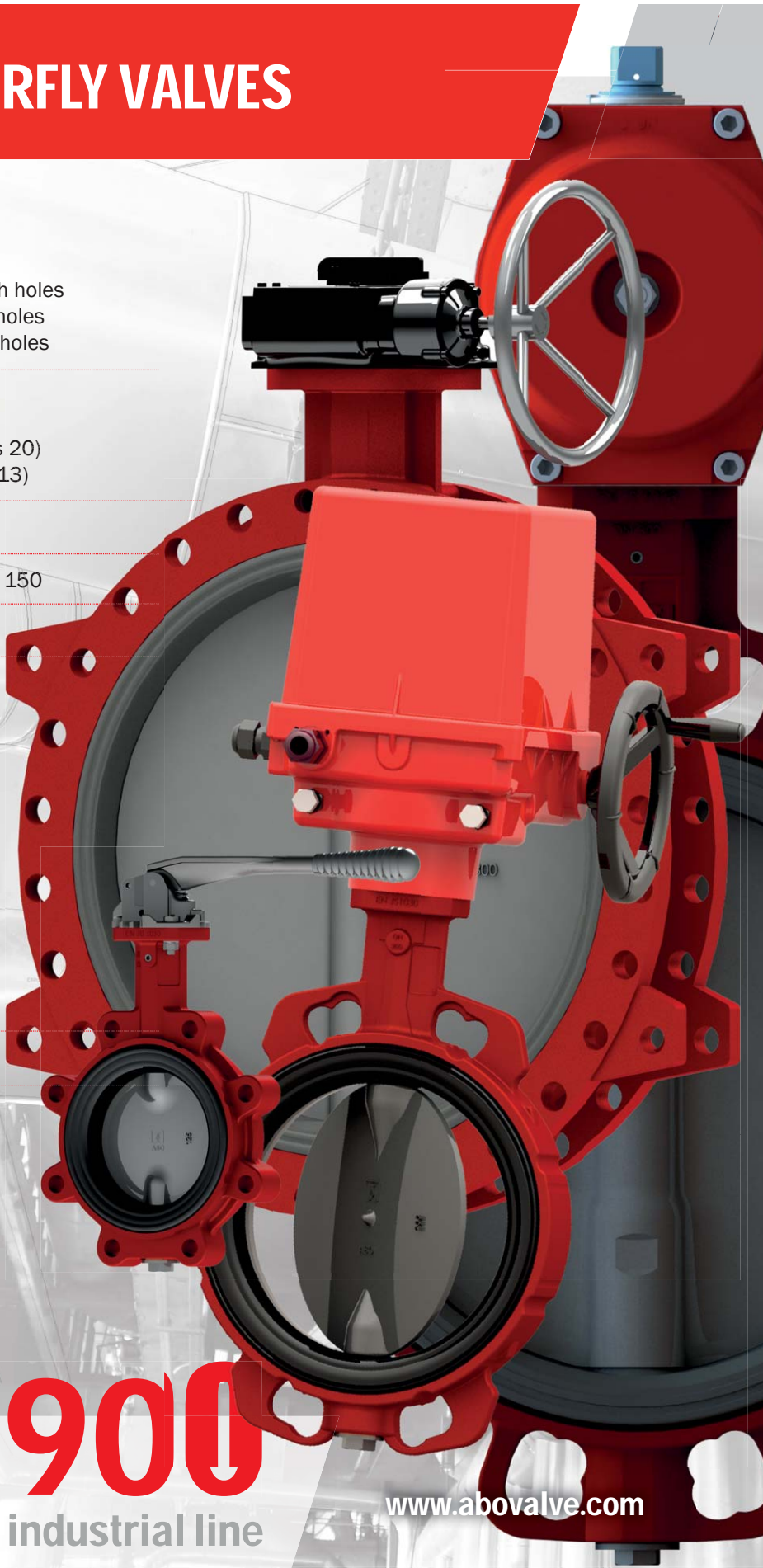

GENERAL VALVE DESCRIPTION

Industrial Valve Manufacturer

Wafer/Lug/Double flanged concentric butterfly valves of Series 900 are resistant soft-sealing valves designed for industrial applications like:

- purification, treatment and distribution of potable or waste water, waste slurry treatment
- heating, heating water distribution
- ventilation, air conditioning
- conveying and distribution of sea and industrial water
- distribution of light chemicals, pharmaceuticals, oils and oil derivatives
- distribution of sugar juice, food industry applications
- conveying loose materials
- pulp and paper industry
- gas distribution
- dust or gas explosive environment (zones 0, 1; 20 and 21; except mining environment)

Basic properties

- concentric design, bidirectional
- wafer/lug type with split stem
- disc is moved by stem with diagonally fit square-end stem
- pivot plug enables to dismantle the valve (valid for wafer/lug valves up to DN 400), pin cover at DN 450-DN 600
- body long neck according to the regulations of thermoprocessing equipment
- red epoxy coating acc. RAL 2002-80 µm
- certified by DWGV for potable water and gas
- ABS certified - PED certificate
- ACS certification

Based on customers' special requests we offer:

- bonded seat - for vacuum systems with maximum absolute pressure of 200 mbar
- NBR conduct - ATEX design for group II, category 1 / 2 GD TX
- special seat types certified by FDA for food industry
- WRAS certification for potable water
- inspection certificates 3.1/3.2
- customer tailored valve design - special body or disc coatings, stem extensions for non-standard valve control etc.

Type designation

9 2 4 B

Body design

- B - Wafer body with through holes
 - T - Lug body with tapped holes
 - U - Double flanged body with short face-to-face length (ISO 5752, Series 20)
 - F - Double flanged body with long face-to-face length (ISO 5752, Series 13)
- * upon request the valve body can be coated with various types of special protecting coatings (Rilsan/Halar/A4 etc.)*

Disc material

- 0 - Brass 2.0402
 - 1 - Aluminium bronze 2.0975 (C95800)
 - 2 - Stainless steel 1.4308 (CF8)
 - 3 - Ductile iron 0.7040 (GGG40)*
 - 4 - Stainless steel 1.4408 (CF8M)*
 - 5 - HASTELLOY
 - 6 - Stainless steel 1.4539 (Uranus B6)
 - 7 - Titanium
- * upon request the disc can be coated with special coatings (Rilsan/Halar)*

Seat material

- 1 - NBR
 - 2 - EPDM
 - 3 - NBR Carboxyle (XNBR)
 - 4 - VITON
 - 5 - Steam silicone (MVQ)
 - 6 - Silicone (VMQ)
 - 7 - Epichlorhydrin (ECO)
 - 8 - HYPALON® (CSM)
 - 9 - NBR 70-AG
- NBR conduct **other materials upon request*

Series designation

Series 900

Standards

Leak test	EN 12266-1, Class A ISO 5208, Class A API 598, Table 5 ANSI/FCI 70-2, Class VI
Face to face length	EN 558, Series 20/13 ISO 5752, Series 20/13 API 609, Table 2
Flange connection	EN 1092-1 ASME B16.5 ASME B16.47
Top flange	EN ISO 5211
Working standard	EN 593 EN 1074-1, 2 DVGW W 363-(P) EN 13774

DESIGN MODELS



INTERFLANGED DESIGN

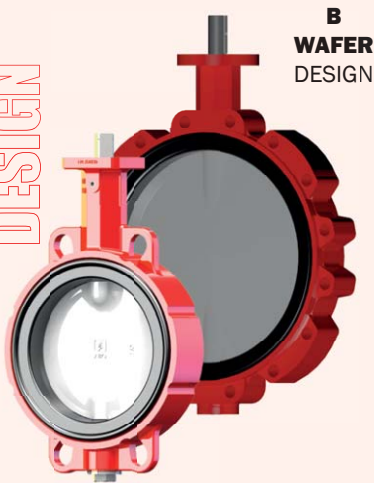

DN32-DN600



DN32-DN600

ATEX CERTIFIED

DOUBLEFLANGED DESIGN

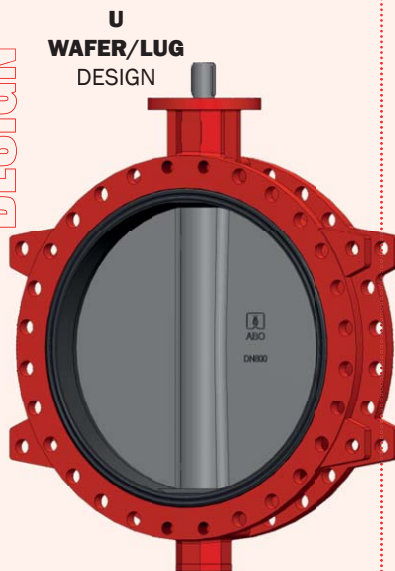

DN700-DN1600
Short face-to-face length
Series 20

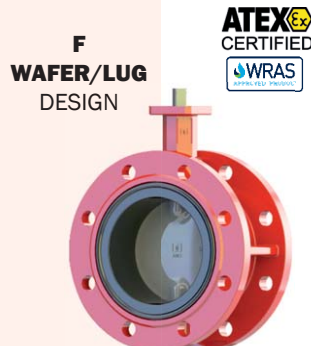

DN50-DN2200
Long face-to-face length
Series 13

ATEX CERTIFIED
WRAS

Quality control

- ABO valve production facilities are certified in accordance with ISO 9001:2015 (ISO 14001, 45001)
- tightness test procedures according to standards EN 12266-1, ISO 5208, ANSI/FCI 70-2
- production in accordance with the Pressure Equipment Directive 2014/68/EU (Module H)
- 3.1, 3.2 inspection certificates
- all the actuators are adjusted and tested while assembled
- manual actuator, if delivered, is adjusted and tested while assembled
- all the certificates can be downloaded from www.abovalve.com

For natural gas interflanged distribution systems

are offered gas versions valves of the Series 99xx. The gas valves are fitted with a control lever with a yellow sleeve. The valves are designed for natural gas, are supplied with a special set of seat with **DVGW** certification, tightness class A, working pressure max. 10 bar.

For distribution of potable water

are offered valves of Series 900 with special set of seats with **DVGW/WRAS** certification. The valves are designed for cold water, inc. potable water, tightness class A, working pressure 10/16 bar. The valves are equipped with control lever with a grey sleeve.

As a lightweight variant (valves with lower weight) are offered valves of Series 900 with aluminium body, working pressure 10/16 bar, working temperature: - 40 °C / +150 °C.

DVGW CERTIFICATION
GAS / POTABLE WATER

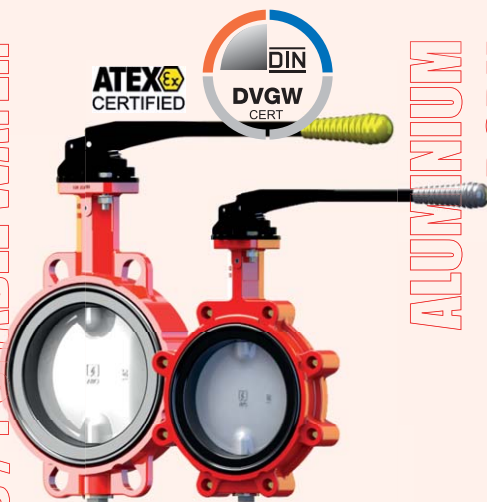

DN32-DN400

ALUMINIUM BODY



DN32-DN300

DESIGN ADVANTAGES

Industrial Valve Manufacturer

INTERFLANGED DESIGN

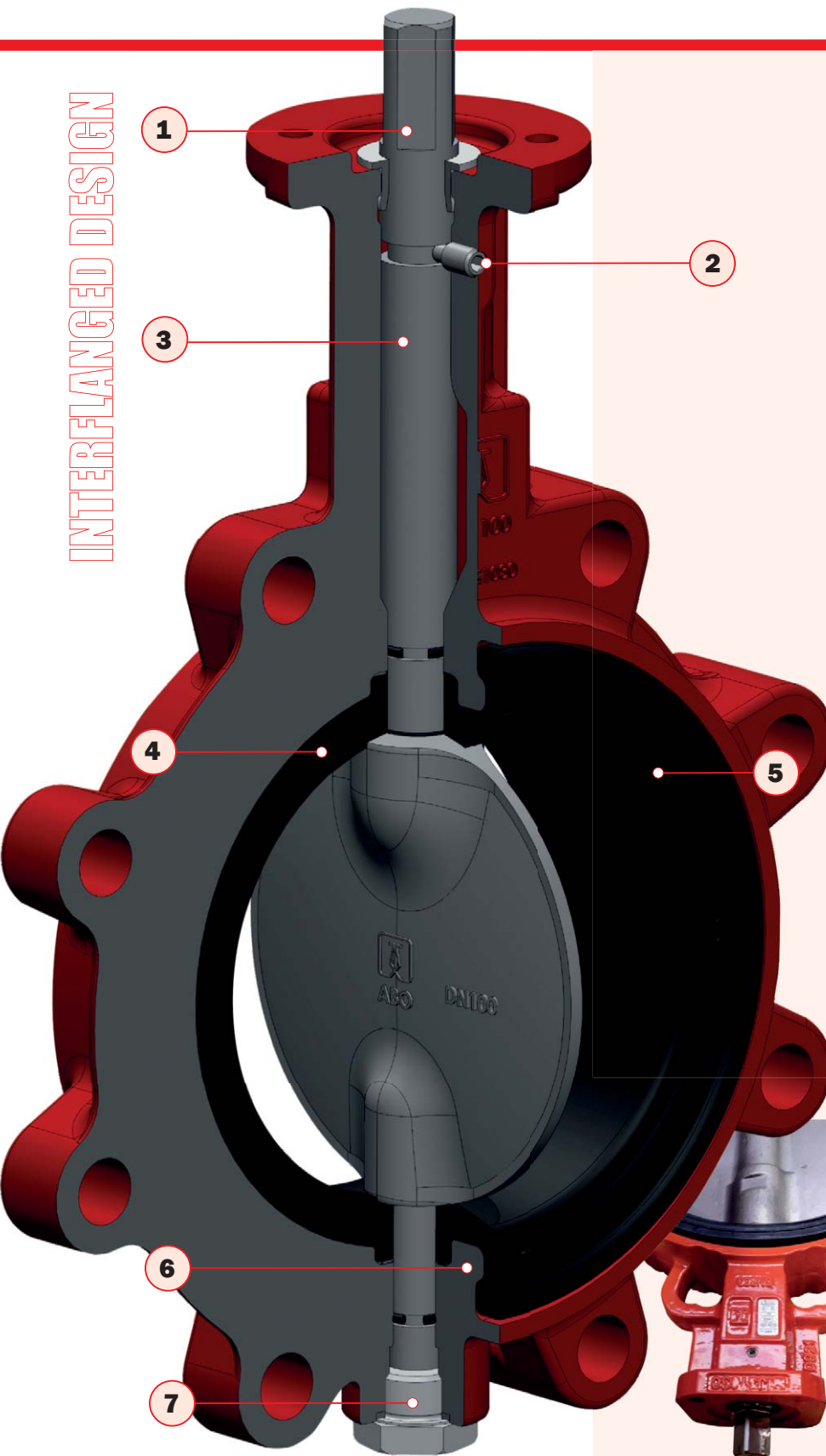

1. International standard compatibility

- according to the standard ISO 5211 top flange enables to directly mount any manual operators and actuators. Valve long neck enables to use insulation and protects control elements on the ISO flange. The design meets requirements on heating system control fittings.

2. Blow-out proof shaft system

- a retaining bolt disables a stem movement upwards

3. Splitted stem

- with the divided stem the valve reaches better Kv/Cv values and thus a low pressure loss.

4. Seat design

- seat profile in the body (groove and tongue system) prevents the seat to slip out from the body when the disc moves.

5. Dougle side profile

- enables to correctly fit the seat in the body

6. Groove shape

- the seat is inserted in the stem position inside the body profile to enable better support.

7. Demountable design

- enables to simply change the seal.



< DN 4 00
retaning washer
against stem
movement

> DN 400
retaining bolt
against stem
blow-out

4 / ABO Valve Czech

BODY SURFACE TREATMENT / SEAT ANCHORING



Body surface treatment

Epoxy coating

Standard ABO high quality epoxy coating system, complying with the C2 corrosion aggressiveness degree according to the standard ČSN EN ISO 12944-1, minimum coating thickness 80 µm.

Marine environment coating

Resistant coating suitable for marine environment or high corrosion risk environment. Available are variants resistant to corrosion aggressiveness grades C3, C4 and C5.

Rilsan

Highly resistant coating for very demanding applications of high flexibility, elasticity and excellent corrosion resistance. This coating option is recommended for applications such as seawater, cement, process water, food or media contaminated with chemicals.

Halar

Thermoplastic Fluoroplast coating to be installed in pipelines with aggressive media. The coatings of high chemical resistance are suitable also for joining material, sealing washers and similar.

Inter Zone 954

Coating provides superior protection in sea water environment. The coating is designed for bodies exposed to high humidity or other very arduous climate conditions. It is highly resistant to acid and solvent vapours and sprinkles, common and salt water.

Seat anchoring options

Groove/tongue

STANDARD

- groove/tongue system prevents seat movement
- reliability
- simple replacing seat

Vulcanized(bonded) seat

UPON REQUEST

- vulcanized seat is intended for use in vacuum and difficult operation conditions. For lower vacuum glued seat version can be used.



The seat is guiding and prevents anchored by **a groove/tongue system** enabling stable unwanted seat movement.

3-stage sealing system guarantees 100% tightness, long term product lifespan and safe operation in the most demanding applications.

1. Primary sealing

- sealing surface of the seat in the contact area with disc, stem and pivot has a precisely defined geometry

2. Secondary sealing

- secondary sealing is created by the stem and pivot disc overlap depending on the seat diameter

3. Tertiary sealing

- stems and pivots are equipped with safety O-rings that further enhance operational performance and reliability
- O-rings protect stem bearings against penetration of abrasive particles from environment

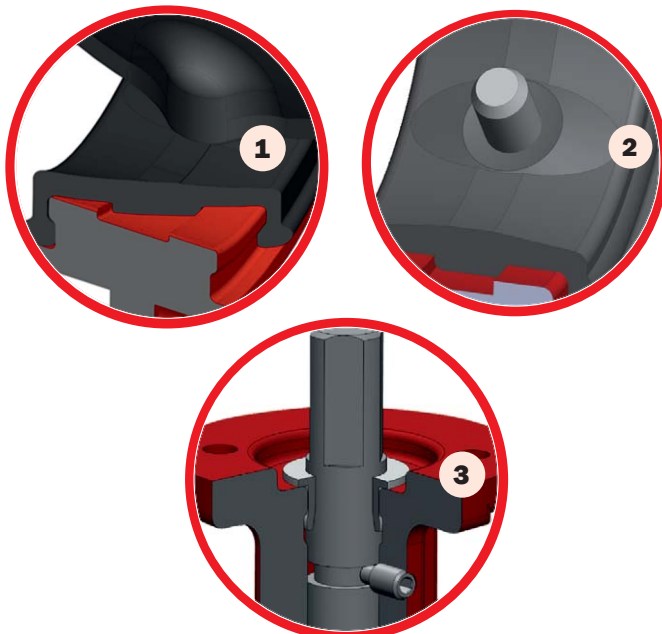

VALVES FOR SPECIAL PURPOSES

Industrial Valve Manufacturer

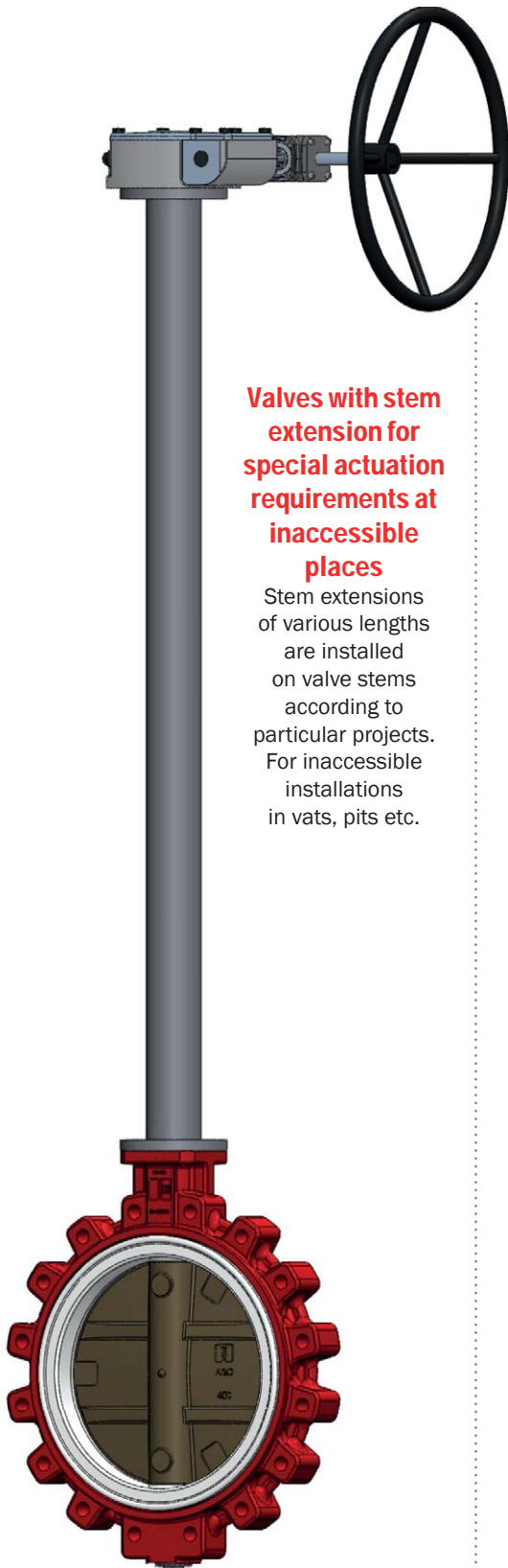

6 / ABO Valve Czech

Valves with stem extension for special actuation requirements at inaccessible places

Stem extensions of various lengths are installed on valve stems according to particular projects. For inaccessible installations in vats, pits etc.



Valves with lightened aluminium body

Light weight valve. Suitable for installations in plastic pipes (pools)



Valve discs with special coatings

Discs are coated with high resistant coatings for aggressive environment (Rilsan/Halar).



Aluminium bronze valve disc for seawater treatment systems

Specially designed for maritime and marine environment where a maximum product reliability is required in highly saline environment.



Polyurethane coated valve bodies

Specially designed for underground applications. Polyurethane coating protects the valve body against corrosion.

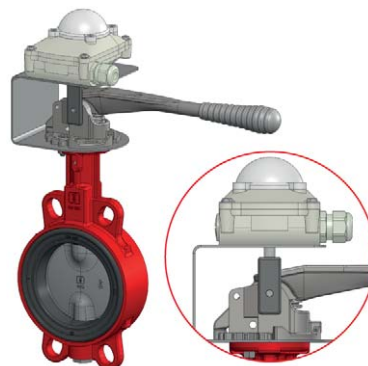

Valve with special lever and limit switches

Can be equipped with non-standard lever type (up to 10 position degrees). The disc position is scanned by limit switches connected to the valve stem.



Valve actuator installation according to customers' requirements

Standard - actuator on the side. Possibility to place valve actuator according the specific disposition or specific requirements.

VALVES FOR SPECIAL PURPOSES



ATEX design

For valves intended for explosive atmospheres i.e where explosive mixtures of gases, vapours, fog or dust are created. DVGW certification.



Valves with worm gear controlled by chain

Chain installed for worm gear control. The chain replaces handwheel. Suitable for inaccessible places.



Valves with FDA certified seats

For food industry. For potable water medium WRAS certification can be provided.



Valve with stem extension

Stem extensions are used in hard-to-reach places where there is no direct access to the valve.



Additional equipment for pneumatic actuators

Pneumatic actuators can be equipped with positioners, solenoids, limit switch boxes, etc.

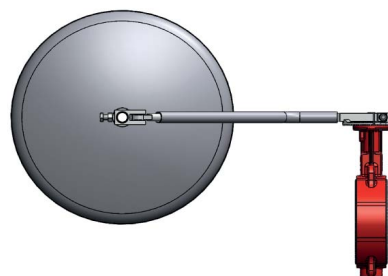

Float valve

For installations in tanks/reservoirs. The float controls valve opening by the level height.



Valves with stainless flanges

Non-standard connection to pipelines. Connection flanges are screwed to the valve body.

[www.abovalve.com /7](http://www.abovalve.com/)

SEATS / POSSIBLE APPLICATIONS

Industrial Valve Manufacturer



Industry	Medium	Marking	Seat material	Applications	Working temperature range
Water management Potable water treatment	Potable water	EPDM	DRINKING WATER EPDM (EPDM-018)	WRAS, ACS. Certified by DVGW GmbH (DVGW W 363-P).	-20 °C .. + 90 °C
Water management Potable water distribution / Heating	Potable water Heating water		DRINKING WATER EPDM-HT (EPDM-019)	For potable water purification, treatment and distribution - higher temperature resistance	-20 °C .. + 130 °C
Water management Potable water distribution / Food indust	Beverages Juices / Malt Hot service water		EPDM-HT*) (EPDM-022)	FDA certified. For sugar mills, beverage factories, malt houses. Seat colour - black.	-20 °C .. + 130 °C
Food industry	Beverages Juices Malt		EPDM-014 (FDA)	FDA certified - for lower tempetaure ranges. Seat colour - white. Corresponds to standard 1935/2004.	-10 °C .. + 90 °C
Chemical industry Ventilation Air conditioning Water treatment	Air Non-aggressive acids and alkalines Non-aggressive minerals Water distribution		EPDM-008/1	For distribution of non-aggressive mild mineral acids, air distribution - ventilation and air conditioning. Suitable for water treatment installations..	-20 °C .. + 90 °C
Water managment	Potable water	EPDM	EPDM-024 NSF61	For potable water purification, treatnet and distribution - higher temperature	-20 °C .. + 130 °C
Industrial production processes / Gas distribution Oil industry Petrochemi- stry Fuel processing Waste oils processing Fat sorting Loose materials conveying Cement and lime industry	Gas	NBR	DVGW-GAS NITRILE	Natural gas transport and distribution. Certificated by DVGW CERT GmbH	-10 °C .. + 90 °C
		NBR-X	CARBOXYLIC NITRILE	For oily media applications with brasive particles in transported media. FDA.	0 °C .. + 90 °C
	Abrasive media	FLUCAST	FLUCAST AB/N	For oily mediaainstallations - crude oil distribution	-0 °C .. + 90 °C
		FLUCAST	FLUCAST AB/P	For abrasive resistant applications - for „dry“ media like loose materials, powder media (gypsum, carbon black, china clay, oxides), pneumatic conveying of cement and powder in mining industry.	-10 °C .. + 70 °C
		FLUCAST	FLUCAST AB/T	For abrasive media with high temperature resistance.	-5 °C .. + 130 °C



*) **EPDM Super HT seat:** -10 °C .. +150 °C. This new EPDM Super HT seat has much better mechanical properties if we compare it to other rubber compounds used at high temperatures like silicones of fluorelastomers. In addition to being used for hot water, EPDM Super HT is also suitable for steam. Here it can replace f.e. steam silicone seat

Industry	Medium	Marking	Seat material	Applications	Working temperature range
Sea water treatment Water softening for industry in general Petrochemistry Fuel processing Biogas distribution	Salt water Biogas Crude oil Fuel	ECO	EPICHLORHYDRIN	For seawater, saltwater, gas/biogas, crude oil and fuel distribution applications.	-40 °C .. +90 °C
Chemical industry Recove- ry / Stem heating / Biogas distribution / System for production and distri- bution of pure steam	Steam Biogas Agressive acids Oils	FPM	VITON BIO	High fluorine contents, suitable for distribution of acids and oils, chemically resistance.	-5 °C .. +150 °C
			STANDARD VITON (FPM-002)		
Chemical industry Petrochemistry	Industrial grease Oils Non-agressive acids	CSM	HYPALON	Suitable for applications with standard rubber mixtures lifespan limited by action of high temperatures - distribution of oils, diluted acids and alka- lines.	-10 °C .. +100 °C
Chemical industry Recovery Steam heating Industrial pipelines for steam distribution	Steam	MVQ	HYPALON	For heat recovery, steam supply and distribution systems	-40 °C .. +150 °C
Food industry	Food steam	VMQ	FOOD SILICONE	Steam distribution systems with higher work temperatures, certified by FDA.	-40 °C .. +150 °C
Chemical industry Recovery Steam heating Industrial pipelines for steam distribution	Steam - high temperature ranges	VMQ	SILICONE	For media requiring higher temperature resistance at negative and positive work media temperatures (steam).	-40 °C .. +160 °C

*) possible alternatives of the seats with WRAS certification:

1. Material EPDM, type designation **YL-E-7010**, black color of the seat, for temperature ranges max. 60 °C.
2. Material EPDM, type designation **Sunaflex T 9635**, black color of the seat, for temperature ranges max. 85 °C.



MATERIAL PERFORMANCE

Industrial Valve Manufacturer

INTERFLANGED DESIGN

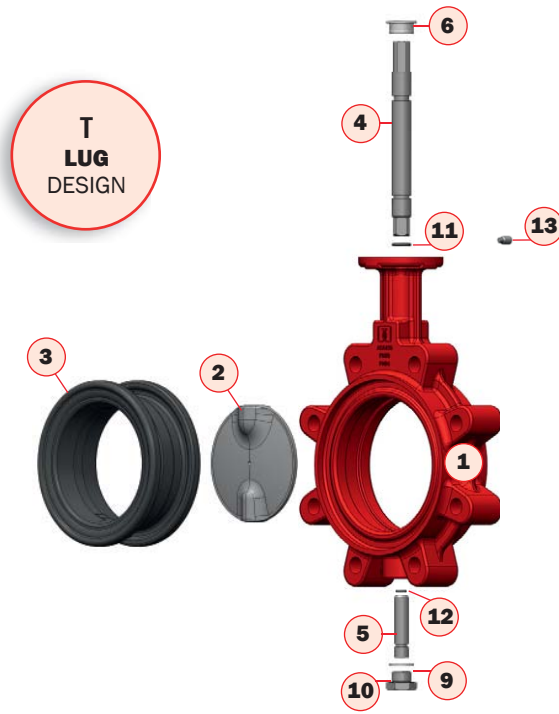

Pos.	Name	Material
1	Body	Ductile iron 0.7040 (GGG40 epoxy coated)
		Carbon steel 1.0446 (A216 WCB)
		Stainless steel 1.4408 (CF8M)
		Low carbon steel 1.1156 (LCC)
		Aluminium EN AC 4300 (C95500)
		Aluminium bronze 2.0975 (C95800)
2	Disc	0 - Brass 2.0402 (UNS C38000)
		1 - Aluminium bronze 2.0975 (C95800)
		2 - Stainless steel 1.4308 (CF8)
		3 - Ductile iron 0.7040 (GGG40) epoxy coated
		4 - Stainless steel 1.4408 (CF8M)
		5 - HASTELLOY
		6 - Stainless steel 1.4539 (Uranus B6)
		7 - Titaniu

Pos.	Name	Material
1	Seat	1 - NBR
		2 - EPDM
		3 - NBR Carboxyl
		4 - Viton Bio
		5 - Silicone steam (MVQ)
		6 - Silicone (VMQ)
		7 - Epichlorohydrin
		8 - HYPALON® (CSM)
		9 - NBR 70-AG - NBR conduct
		Stainless steel 1.4021 (AISI 420)
		Stainless steel 1.4021 (AISI 420)
		Delrin (to DN 300)
		Brass (from DN 350)
4	Stem	Klingersil C-4400)
		Stainless steel A2
5	Pivot plug	NBR, EPDM, optionally VITON
		NBR, EPDM, optionally VITON
6	Bushing	Stainless steel A2
9	seal	
10	plug	
11	Stem O-ring	
12	Pivot O-ring	
13	Retaining bolt	

Other materials upon request.
Seat and disc materials are recommended based on particular inquiry.

INSTALLATION BETWEEN FLANGES



Installation between flanges DN32 to DN600 - Wafer/Lug design

DN		32/40	50	65	80	100	125	150	200	250	300	350	400	450	500	600
B	PN6											•	•	•	•	•
	PN10															
	PN16													•		
	Class150													•	•	•
T	PN6	•	•	•	•	•	•	•	•	•	•	•	•	•	•	•
	PN10													•	•	•
	PN16								•	•	•	•	•	•	•	•
	Class150	•	•	•	•	•	•	•	•	•	•	•	•	•	•	•

Standard
• Upon request
X Impossible

Installation between flanges DN700 to DN1600 - Double flanged design - Series 20

Dn		700	800	900	1000	1100	1200	1300	1400	1500	1600
U	PN6	•	•	•	•	•	•	•	•	•	•
	PN10										
	PN16	•	•	•	•	•	•	•	•	•	•
	Class 150	•	•	•	•	•	•	•	•	•	•

Standard
• Upon request

Installation between flanges DN50 - DN2200 - Double flanged design - Series 13

DN		50 - 2200
F	PN6	•
	PN10	
	PN16 *)	•
	Class 150	•

• Upon request
Standard

*) PN16 for nominal sizes DN50-300 is standard, for nominal sizes bigger than DN300 PN16 upon request



VALVE ACTUATION

Industrial Valve Manufacturer

All the ABO valves can be equipped with hand levers, worm gears, pneumatic and electric actuators. The top flange design according to the standard ISO 5211 enables to directly assemble actuators on valves. Thus compatibility between valves and actuators is guaranteed.

Handlever

For manual actuation ABO offers carbon steel lever suitably painted to improve resistance to corrosion, abrasion and shock. Stainless lever on request. Top flange connection according to ISO standards F05 for DN50 to DN65 and F07 for DN80 to DN200. Controlled lever upon request. The levers can be equipped with a lock to ensure an optimized position. The levers can be supplemented with limit switches.

Dimensions are mentioned in mm, weight in kg.

DN	32-100	125	150 - 200	250	300
A	270	270	362	450	750
B	75	75	75	135	135
Weight	1,24	1,26	1,40	2,20	3,10
Shaft	14x14	17x17	17x17	22x22	22x22

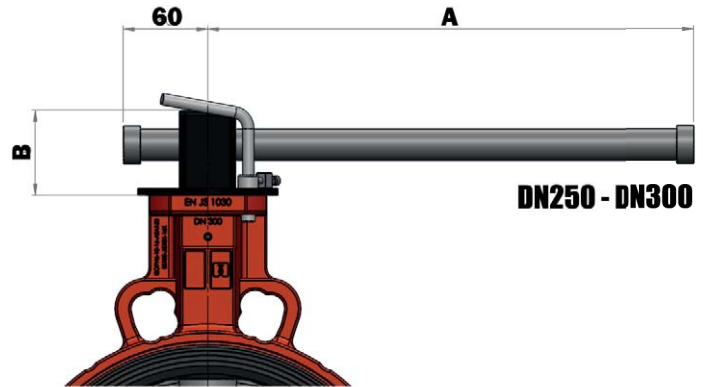
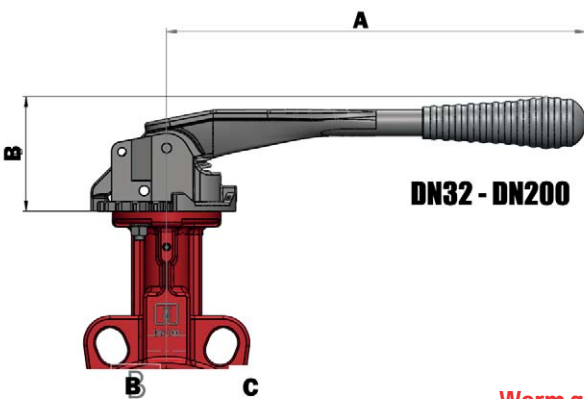

Worm gear with handwheel

Manual gearbox casing is made from cast iron with suitable surface treatment and protection degree class IP 67. Self-locking design of the worm gear enables both to set basic positions open/shut and to control (throttle) media flow. The worm gearbox is simply controlled hand-wheel of a suitable diameter. End positions of the worm gearbox are adjusted by screws. The gearbox can be equipped with a lockable system secured by a padlock. The worm gearbox as well as the hand lever can be completed with limit switch boxes.

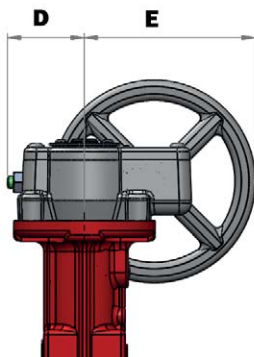
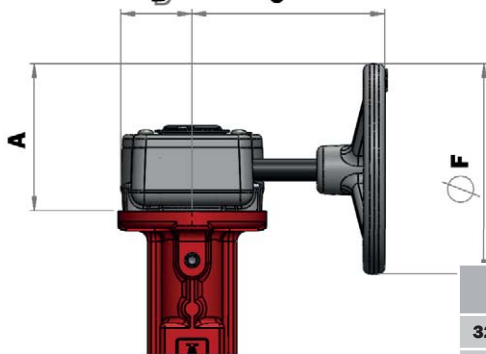

DN	PN	ISO FLANGE	SHAFT	A	B	C	D	E	F	Kg
32/40	16	F05	14X14	70	35	91	38	84	100	1,2
50	16	F05	14X14	70	35	91	38	84	100	1,2
65	16	F05	14X14	70	35	91	38	84	100	1,2
80	16	F05	14X14	70	35	91	38	84	100	1,2
100	16	F05	14X14	70	35	91	38	84	100	1,2
125	16	F07	17X17	127,5	46	139	59	141	200	2,2
150	16	F07	17X17	127,5	46	139	59	141	200	2,2
200	16	F07	17X17	127,5	46	139	59	141	200	2,2
250	16	F10	22X22	134	57	156	60	155	200	4,2
300	16	F10	22X22	134	57	156	60	155	200	4,2
350	10	F12	27X27	183	57	210	95	205	300	4,5
350	16	F12	27X27	238	67	255	131	267	400	6,5
400	10	F14	27X27	292	78	350	169	331	500	11,0
400	16	F14	27X27	341	78	350	219	381	600	12,00
450	10	F14	Ø38	348	110	346	196	405	600	26,00
450	16	F14	Ø38	348	110	346	196	405	600	26,00
500	10	F14	Ø42	348	110	346	196	405	600	26,00
500	16	F14	Ø42	405	143	387	220	480	700	35,00
600	10	F16	Ø50	405	143	387	220	480	700	35,00
600	16	F16	Ø50	405	143	387	270	530	800	37,00

VALVE ACTUATION



Actuators

Pneumatic actuators

Pneumatic actuators ABO Series 95 can be assembled to valves in two options: single-acting or double-acting

Electric actuators

Electric drives ABO Series 97 are designed quarter-turn. Electric actuators can be installed on ABO valves for voltages of 24 V, 230 V or 400 V.

Special actuators types

Valves are equipped with special actuator types from major world suppliers (Auma, Regada, Valpes etc.).



electric actuator

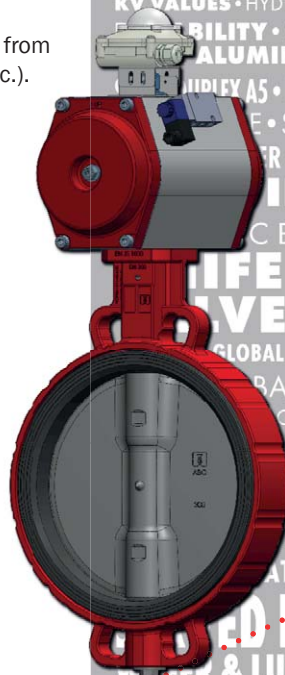

pneumatic actuator

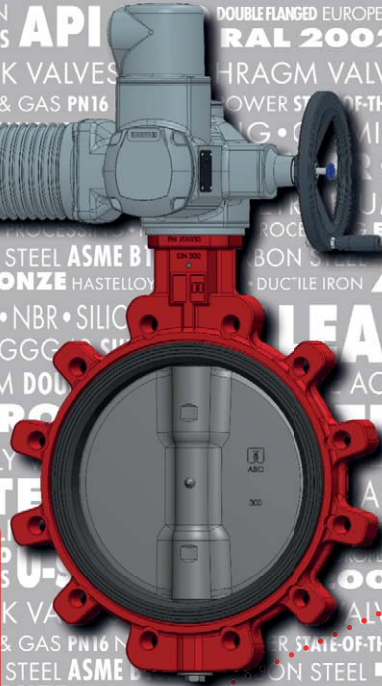

special actuators

Operating torques (Nm) vs working pressure (bar)

DN	32/40	50	65	80	100	125	150	200	250	300	350	400	450	500	600
p_{max} 6bar	8	11	15	20	38	55	70	100	160	235	480	750	1180	1380	2050
p_{max} 10bar	9	12	17	25	46	70	80	125	200	290	530	1200	1550	2050	2700
p_{max} 16bar	10	12	20	30	55	85	100	150	290	380	580	1650	2100	2700	3700

Mentioned torques are valid only for valves with EPDM seats and stainless discs for liquid media. For valve actuation the declared values must be multiplied by 1,2. For NBR seats to be multiplied by 1,4. For gas media or media with abrasive particles use secondary coefficient 1,35. For NBR and VITON (FPM) seats multiply by 1,4. For specific work conditions contact manufacturer to get advised the actuation type choice.

MADE IN EUROPE 100% TESTED
CONCENTRIC BUTTERFLY VALVES

HIGH PERFORMANCE BUTTERFLY VALVES

KNIFE GATE VALVES • CHECK VALVES • BALL VALVES DN150

ATEX 94/9/EC OFFSET DESIGN R&D CENTER GLOBAL OPERATIONS API 598

DN600 • BALL CHECK VALVES • DIAPHRAGM VALVES • FILTERS

• ACTUATORS • POWER • OIL & GAS PN16 NUCLEAR POWER STATE-OF-THE-ART TECHNOLOGY

SERVED INDUSTRIES REFINING • CHEMICAL CLASS 150

WAFFER & LUG TYPE • WASTEWATER • PETROLEUM • OILFIELD

KV VALUES • HYDROCARBON PROCESSING • INDUSTRIAL PROCESSING EPOXY COATING

DURABILITY • STAINLESS STEEL ASME B16.5 • CARBON STEEL

ALUMINIUM BRONZE HASTELLOY TITANIUM DUCTILE IRON

TRIPLE A5 • HYPALON • NBR • SILICONE RUBBER

• STELLITE • GGG40

• MEDIUM DOUBLE OFFSET AGGRESSIVE ACIDS URANUS B6

CONCENTRIC BUTTERFLY VALVES

KNIFE GATE VALVES • CHECK VALVES • BALL VALVES

ATEX 94/9/EC OFFSET DESIGN R&D CENTER GLOBAL OPERATIONS API 598

DN600 • BALL CHECK VALVES • DIAPHRAGM VALVES • FILTERS

• ACTUATORS • POWER • OIL & GAS PN16 NUCLEAR POWER STATE-OF-THE-ART TECHNOLOGY

SERVED INDUSTRIES REFINING • CHEMICAL CLASS 150

WAFFER & LUG TYPE • WASTEWATER • PETROLEUM • OILFIELD

KV VALUES • HYDROCARBON PROCESSING • INDUSTRIAL PROCESSING EPOXY COATING

DURABILITY • STAINLESS STEEL ASME B16.5 • CARBON STEEL

ALUMINIUM BRONZE HASTELLOY TITANIUM DUCTILE IRON

TRIPLE A5 • HYPALON • NBR • SILICONE RUBBER

• STELLITE • GGG40

• MEDIUM DOUBLE OFFSET AGGRESSIVE ACIDS URANUS B6

CONCENTRIC BUTTERFLY VALVES

KNIFE GATE VALVES • CHECK VALVES • BALL VALVES

ATEX 94/9/EC OFFSET DESIGN R&D CENTER GLOBAL OPERATIONS API 598

DN600 • BALL CHECK VALVES • DIAPHRAGM VALVES • FILTERS

• ACTUATORS • POWER • OIL & GAS PN16 NUCLEAR POWER STATE-OF-THE-ART TECHNOLOGY

SERVED INDUSTRIES REFINING • CHEMICAL CLASS 150

WAFFER & LUG TYPE • WASTEWATER • PETROLEUM • OILFIELD

KV VALUES • HYDROCARBON PROCESSING • INDUSTRIAL PROCESSING EPOXY COATING

DURABILITY • STAINLESS STEEL ASME B16.5 • CARBON STEEL

ALUMINIUM BRONZE HASTELLOY TITANIUM DUCTILE IRON

TRIPLE A5 • HYPALON • NBR • SILICONE RUBBER

• STELLITE • GGG40

• MEDIUM DOUBLE OFFSET AGGRESSIVE ACIDS URANUS B6

CONCENTRIC BUTTERFLY VALVES

KNIFE GATE VALVES • CHECK VALVES • BALL VALVES

ATEX 94/9/EC OFFSET DESIGN R&D CENTER GLOBAL OPERATIONS API 598

DN600 • BALL CHECK VALVES • DIAPHRAGM VALVES • FILTERS

• ACTUATORS • POWER • OIL & GAS PN16 NUCLEAR POWER STATE-OF-THE-ART TECHNOLOGY

SERVED INDUSTRIES REFINING • CHEMICAL CLASS 150

WAFFER & LUG TYPE • WASTEWATER • PETROLEUM • OILFIELD

KV VALUES • HYDROCARBON PROCESSING • INDUSTRIAL PROCESSING EPOXY COATING

DURABILITY • STAINLESS STEEL ASME B16.5 • CARBON STEEL

ALUMINIUM BRONZE HASTELLOY TITANIUM DUCTILE IRON

TRIPLE A5 • HYPALON • NBR • SILICONE RUBBER

• STELLITE • GGG40

www.abovalve.com/13

VALVE BASIC DIMENSIONS

Industrial Valve Manufacturer

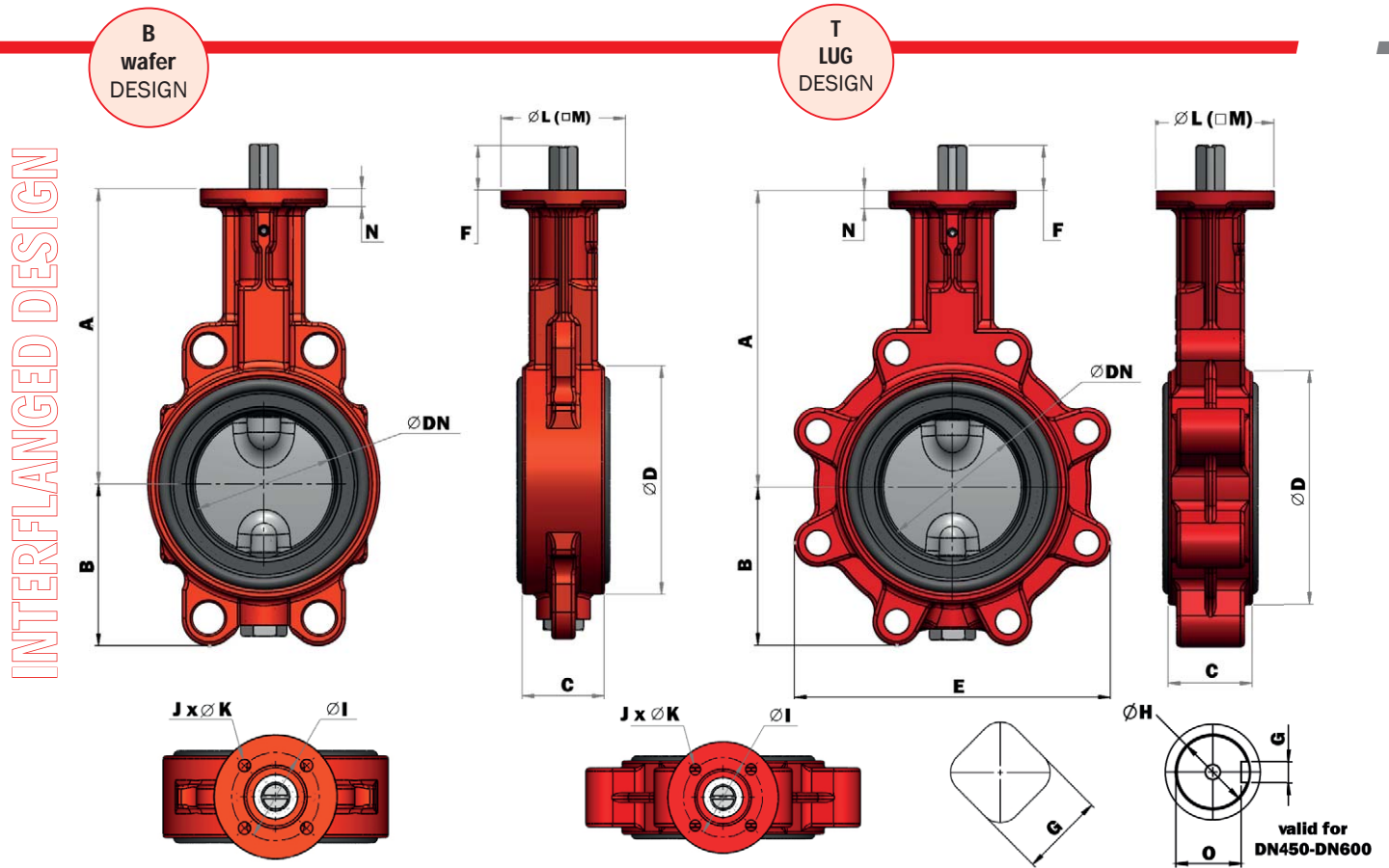

	DN	32/40	50	65	80	100	125	150	200	250	300	350	400	450	500	600
Valve dimensions	A	136	146	154	163	173	193	205	234	270	310	325	365	375	485	565
	B	54	64	72	89	105	119	130	166	202	237	271	314	330	368	464
	C	33	43	46	46	52	56	56	60	68	78	78	102	114	127	154
	D	78	96	113	128	150	184	212	268	320	378	435	488	544	590	695
	E	110	115	129	174	204	234	255	319	396	465	509	590	610	682	810
Endshaft dimensions	F	25	25	25	25	25	25	25	25	30	30	36	36	80	80	80
	G	14	14	14	14	14	17	17	17	22	22	27	27	12	12	14
	H	-	-	-	-	-	-	-	-	-	-	-	-	ø42	ø42	ø50
	O	-	-	-	-	-	-	-	-	-	-	-	-	37,1	37,1	44,5
Flange dimensions	I	50/70	50	50	50	50	70	70	70	102	102	125	140	140	140	165
	J	4	4	4	4	4	4	4	4	4	4	4	4	4	4	4
	K	7	7	7	7	7	9	9	9	11	11	14	18	18	18	23
	L	-	70	70	70	70	-	-	-	-	-	-	-	175	175	210
	M	70	-	-	-	-	70	70	70	105	105	130	140	-	-	-
Weight (kg)	N	8	8	8	8	8	12	12	14	17	17	17	21	22	27	27
	ver. B	2,3	2,7	3,2	3,7	4,7	6,7	8,4	13,3	22,0	29,3	46,4	69,8	83,0	112,0	216,0
	ver. T	2,3	3,0	3,7	4,8	6,1	9,2	10,2	15,3	28,4	41,2	62,0	96,3	130,0	149,0	288,0
ISO Flange		F05/07	F05	F05	F05	F05	F07	F07	F07	F10	F10	F12	F14	F14	F14	F16

Dimensions are mentioned in mm.

NOMINAL FLOW VALUES



DN	10°	20°	30°	40°	50°	60°	70°	80°	90°
32/40	0,1	2	4	9	17	30	45	61	84,4
50	0,1	3	6	11	23	50	81	110	147
65	0,1	5	10	21	53	90	160	210	290
80	0,2	8	15	33	76	160	238	340	450
100	0,3	20	35	60	122	220	362	520	730
125	0,4	24	60	110	223	430	626	797	1260
150	0,7	54	105	248	400	640	987	1630	1990
200	2	120	210	410	915	1630	2331	3446	4396
250	3	129	274	590	1037	2000	3210	4164	4500
300	3	188	424	820	1500	2710	4180	5433	6800
350	5	265	685	1327	1990	3214	4690	6292	8900
400	7	345	1000	1825	2550	4383	6090	9779	11500
450	9	449	1200	2518	3680	5929	7840	11925	15000
500	12	586	1511	2909	4340	7167	9508	12762	18800
600	19	847	2217	4203	6560	9863	14614	23621	27600
700	31	1554	3118	5686	8569	12810	19511	29904	42416
800	39	2045	4105	7486	11815	17633	29902	41231	52776
900	53	2614	5767	10917	17326	27849	44987	68209	74979
1000	72	3584	7194	13117	20702	30991	47201	72344	102614
1200	390	4597	10146	19195	26221	43873	79092	119966	131962

1KV = 0,854701 CV

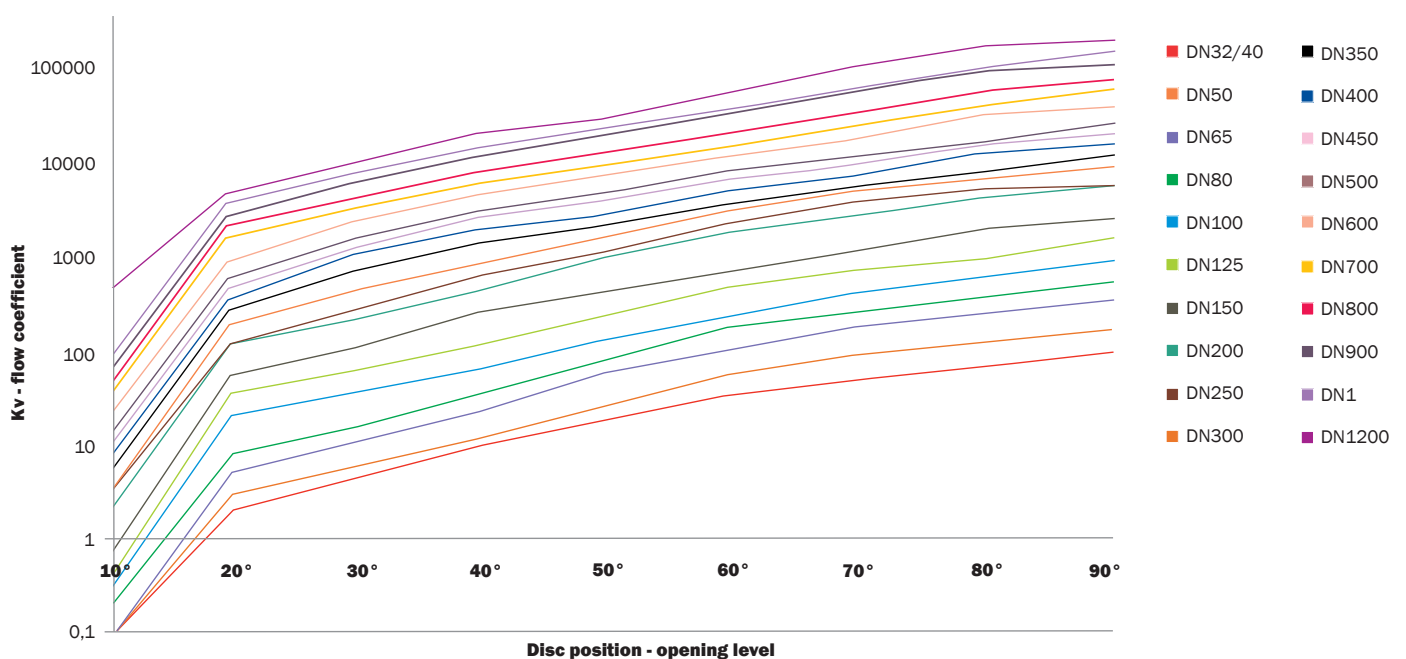

DN>600 / DOUBLE FLANGED DESIGN - SERIES „U”

Industrial Valve Manufacturer

Body design

Double flanged Body with threaded / tapped holes

Design performance

Series „U” Short face-to-face length, Series 20
According to ISO 5752-20

Nominal size

Design „U” DN700 - DN1600

Working pressure

1,0 MPa - 1,6 MPa (PN10 / PN16)

Leak test

1,1 MPa - 1,76 MPa

Working temperature

NBR -10 °C / +90 °C
Seat EPDM -20 °C / +125 °C *)

Features

Concentric design

Top flange according to ISO 5211
Flange connection according to BS4504/DIN/ANSI
Design complies with API609

*) other alternatives upon request

1. International

Standard compatibility

- according to the standard ISO 5211 the top flange enables to directly assemble any manual operators and actuators. Valves are usually delivered with worm gear actuators. A wide scale of pneumatic or electric actuators can be assembled, too.

2. Blow-out proof system

- a retaining washer disables shaft movement upwards.

3. Lengthened neck

- enables to insulate the actuator from conveyed media warm effects and thus meets requirements on heating systems controls

4. Seat design

- seat movement or incorrect position is impossible - seat can be vulcanized. Vulcanization leads to decreasing torque values needed to handle the valve. Valve inner part is fully rubber lined and thus protected against corrosive effects.

5. Disc design

- disc with polished edges is protective to seat and provides a long lifespan. Symmetric disc profile improves valve performance by increasing Kv (Cv) values, decreases turbulence and minimizes pressure loss

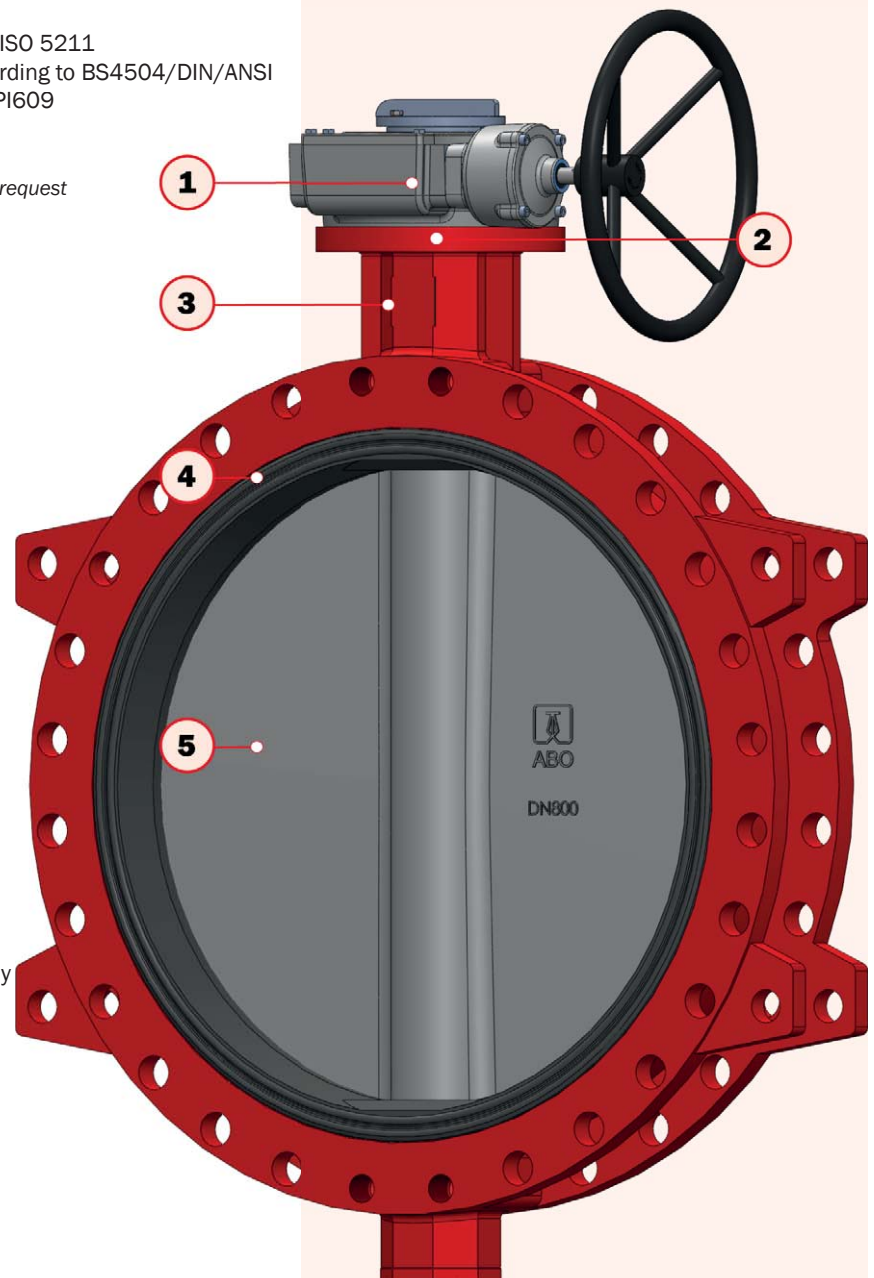

DN>600 / DOUBLE FLANGED DESIGN - SERIES „U“



DN700-DN1600 / PN10

Pos	Name	Material
1	Body	0.7040
2	Disc	upon request
3	Seat	upon request
4	Shaft	1.4021
5	Pivot	1.4021
6	Bushing	Bronze
7	Supporting liner	1.4301
8	Retaining ring	1.4401 (316)
9	Cover	0.7040
10	Washer	1.4301 (304)
11	Washer	1.4301 (304)
12	Bearing	upon standard
13	O-ring	upon request
14	O-ring	upon request
15	O-ring	upon request
16	Washer	A4
17	Bolt	A4
18	Bolt	A4
19	Spring	A4

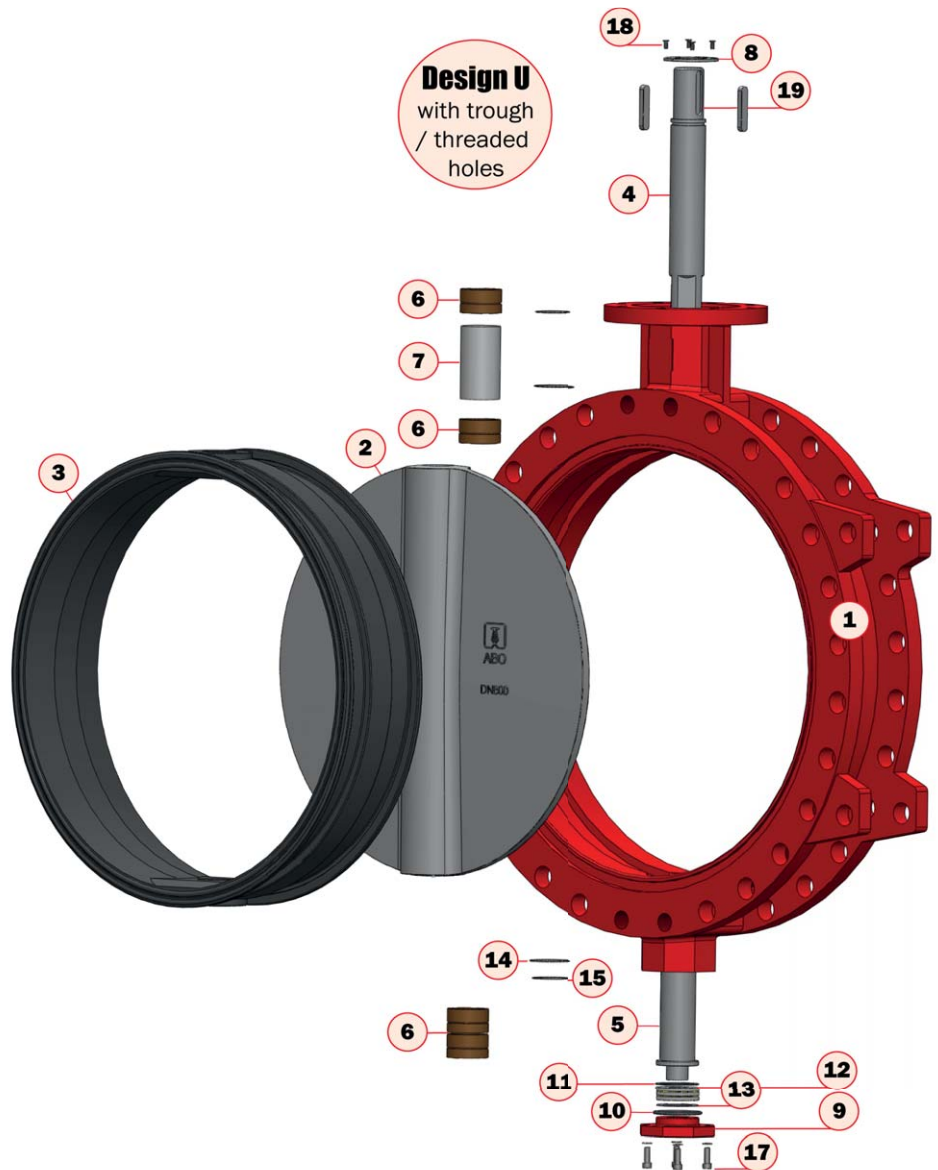

Advantages of concentric shut-off valve double-flanged design

- 100 % tightness
- 0% leakiness
- vulcanized seat
- actuation by various actuator types - manual, electric, pneumatic or special types
- on/off and for regulation
- fully sealed stem, medium is not in contact with stem and body
- bi-directional tightness
- low body weight
- disc aerodynamic design minimising pressure loss
- disc with polished edges, high through put profile

Material options Body / Disc / Seat/ Shaft

Body	Grey cast iron / Ductile iron / Carbon steel / Stainless steel / Epoxy coating / Coating C4, C5
Disc	Ductile iron / Stainless steel / Aluminium Bronze / Duplex / Super Duplex / HC276 / RILSAN, HALAR coating
Seat	NBR / EPDM / EPDM for potable water/FPM/Silicone
Shaft	AISI420 / AISI431 / F51/ F55 or

*) special materials upon request

DN>600 / DOUBLE FLANGED DESIGN - SERIES „U”

Industrial Valve Manufacturer

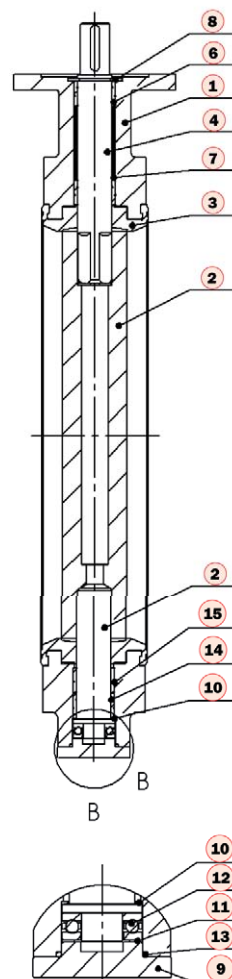
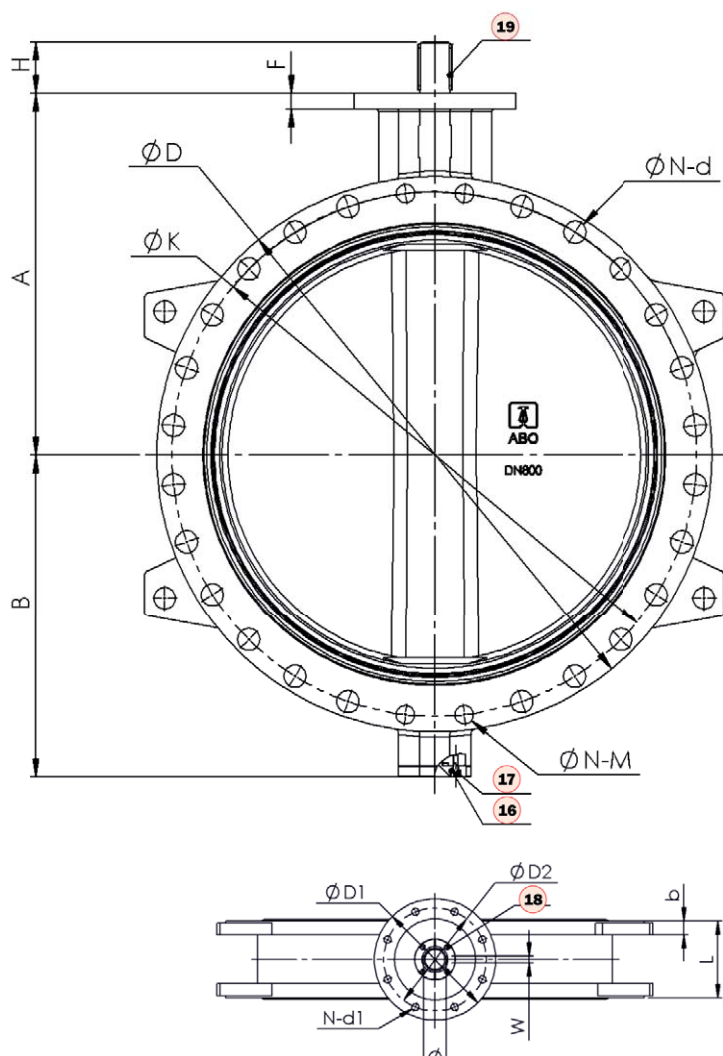

DN700 - DN1600 / PN10

	700	800	900	1000	1100	1200	1400	1600
A	624	672	720	800	900	941	1040	1150
B	535	606	670	735	830	978	1009	1138
H	95	95	130	130	135	150	150	180
D	910	1025	1125	1255	1355	1485	1685	1930
K	840	950	1050	1160	1270	1380	1590	1820
N-d	20-31	20-34	24-34	24-37	28-37	28-41	32-44	36-50
N-m	4-M27	4-M30	4-M30	4-M33	4-M33	4-M36	4-M39	4-M45
L	165	190	203	216	254	254	279	318
b	32,5	35	37,5	40	42,5	45	46	49
D1	300	300	300	300	350	350	415	415
D2	254	254	254	254	298	298	356	356
N-d1	8-18	8-18	8-18	8-18	8-22	8-22	8-33	8-33
F	30	30	34	34	34	34	40	40
Ø	55	55	75	85	105	105	120	160
W	16	16	20	22	28	28	32	40

18 / ABO Valve Czech

Dimensions are mentioned in mm.
PN16 / Class 150 upon request

DOUBLE FLANGED DESIGN - SERIES „U”



Operating torques (Nm) vs working pressure (bar) SERIES 20

DN	PN10	PN16
	Nm	Nm
700	3500	4200
750	3800	4800
800	4600	5600
900	5800	7800
1000	8800	10800
1100	11240	15600
1200	13800	19320
1300	16900	23660
1400	20000	28000
1500	25000	35000
1600	29000	40600
1800	39900	55860
2000	52250	73150

Mentioned torques are valid for valves of Series 20 with interchangeable seats. The data do not include values of the safety factor. Using seat EPDM multiply the values by 1,2. Using seats NBR/VITON/SILICONE multiply the values by 1,3.

Operating torques (Nm) vs working pressure (bar) SERIES 13

DN	PN10	PN16
	Nm	Nm
50	17	17
65	25	25
80	38	38
100	56	56
125	90	90
150	124	124
200	233	233
250	392	392
300	560	560
350	736	988
400	1011	1479
450	1355	1887
500	1807	2444
600	2825	4054
700	4410	6204
750	5080	-
800	5812	8782
900	7092	12142
1000	10584	16122
1050	12172	-
1200	16935	29684
1400	22000	345000

Mentioned torques does not include safety factor. Please use a factor of 1.3

VALVE ACTUATION Worm gearbox with handwheel

Manual gearbox casing is made from cast iron with suitable surface treatment and protection degree class IP 67. Self-locking design of the worm gear enables both to set basic positions open/shut and to control (throttle) media flow. The worm gearbox is simply controlled hand-wheel of a suitable diameter. End positions of the worm gearbox are adjusted by screws. The gearbox can be equipped with a lockable system secured by a padlock. The worm gearbox as well as the hand lever can be completed with limit switch boxes.

Actuators

Pneumatic actuators

Two standard designs: single-action/double-action.

Electric actuators

Electric actuators can be installed for voltages of 24 V, 230 V or 400 V

Special actuators types

Made by suppliers Auma, Regada, Valpes, etc

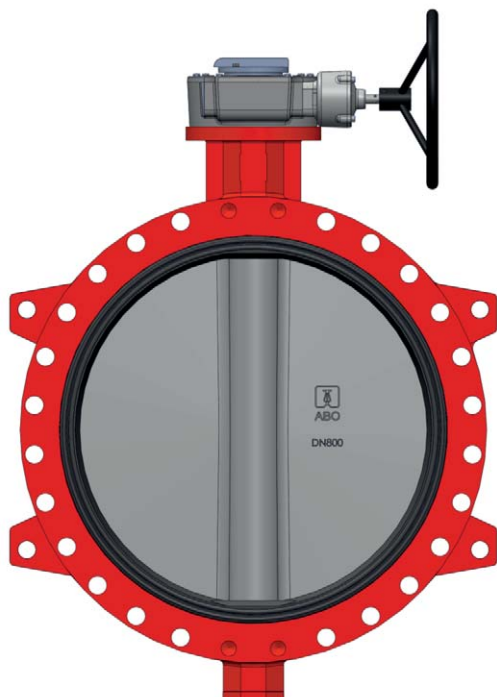

DN>600 / DOUBLE FLANGED DESIGN - SERIES „F“

Industrial Valve Manufacturer

Body design

Double flanged Body with through / threaded holes

Design performance

Increased face-to-face length, Series 13
Series „F“ According to ISO 5752-13

Nominal size

Design „F“ DN50 - DN2200

Working pressure

10 bar - 16 bar (PN10 / PN16)

Leak test

11 bar - 17,6 bar

Working temperature

Seat NBR -10 °C / +90 °C **vulcanized**
Seat EPDM -20 °C / +125 °C **vulcanized ***)

Features

Concentric design

Top flange according to ISO 5211
Flange connection according to S4504/DIN/ANSI
Design complies with API609

*) other alternatives upon request

1. International Standard compatibility

- according to the standard ISO 5211 the top flange enables to directly assemble any manual operators and actuators. Valves are usually delivered with worm gear actuators. A wide scale of pneumatic or electric actuators can be assembled, too.

2. Blow-out proof system

- a retaining washer disables shaft movement upwards.

3. Lengthened neck

- enables to insulate the actuator from conveyed media warm effects and thus meets requirements on heating systems controls

4. Seat design

- seat movement or incorrect position is impossible - seat can be vulcanized. Vulcanization leads to decreasing torque values needed to handle the valve. Valve inner part is fully rubber lined and thus protected against corrosive effects.

5. Disc design

- disc with polished edges is protective to seat and provides a long lifespan. Symmetric disc profile improves valve performance by increasing Kv (Cv) values, decreases turbulence and minimizes pressure loss.

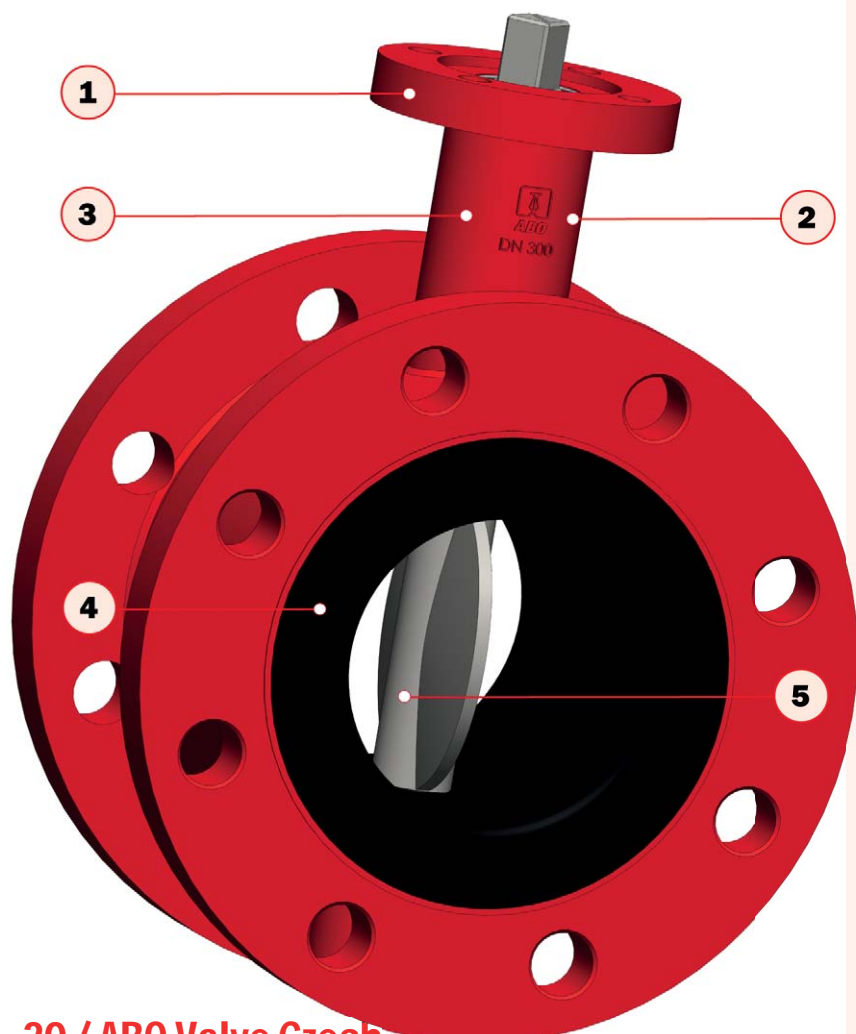

20 / ABO Valve Czech

DOUBLE FLANGED DESIGN - SERIES „F“



ABO valve



DN50-DN2200 / PN10

Pos	Name	Material
1	Body	0.7040
2	Disc	upon request
3	Seat	upon request
4	Shaft	1.4021
5	Pivot	1.4021
6	Bushing	Bronze
7	Supporting liner	1.4301
8	Retaining ring	1.4401 (316)
9	Cover	0.7040
10	Washer	1.4301 (304)
11	Washer	1.4301 (304)
12	Bearing	upon standard
13	O-ring	upon request
14	O-ring	upon request
15	O-ring	upon request
16	Washer	A4
17	Bolt	A4
18	Bolt	A4
19	Spring	A4

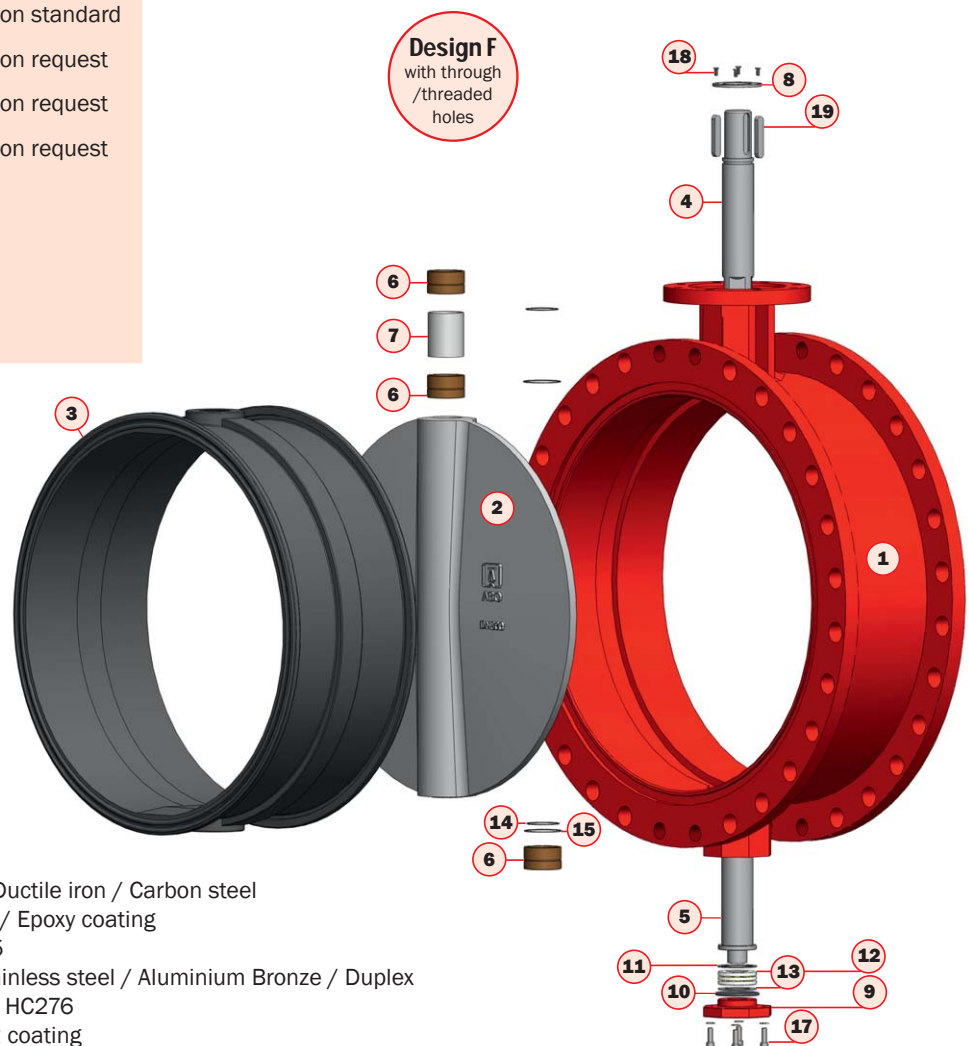

Material options Body / Disc / Seat / Shaft

Body	Grey cast iron / Ductile iron / Carbon steel / Stainless steel / Epoxy coating / Coating C4, C5
Disc	Ductile iron / Stainless steel / Aluminium Bronze / Duplex / Super Duplex / HC276 / RILSAN, HALAR coating
Seat	NBR / EPDM / EPDM for potable water/FPM/Silicone
Shaft	AISI420 / AISI431 / F51/ F55 or

*) special materials upon request

www.abovalve.com /21

DESIGN PARAMETERS

/ SERIES - „F”

Industrial Valve Manufacturer

DN50 - DN350 / PN10

Pos	Name	Material
1	Body	0.7040 + EPDM
2	Bushing	Bronze
3	Pivot	SS 1.4021/420t
4	Disc	1.4408 (CF8M)
5	Rivet	SS A2
6	Label	1.4301/SS304
7	Bushing	Bronze
8	O-ring	EPDM/NBR
9	Washer	1.4301/SS304
10	Retaining ring	SS A2
11	Shaft	SS 1.4021/420

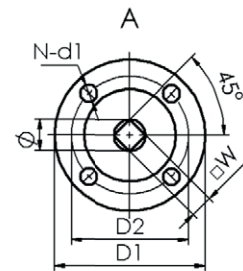
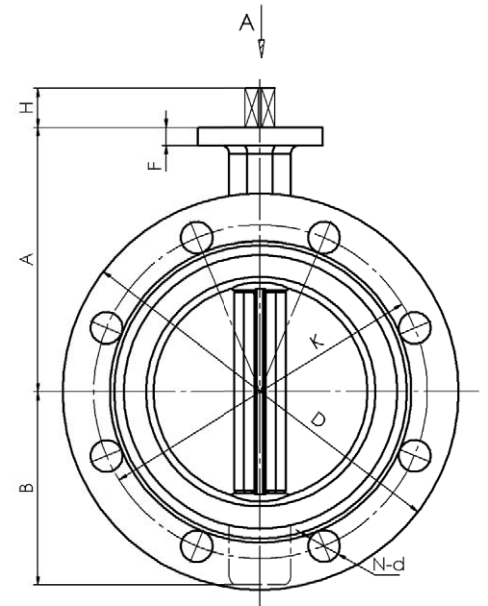
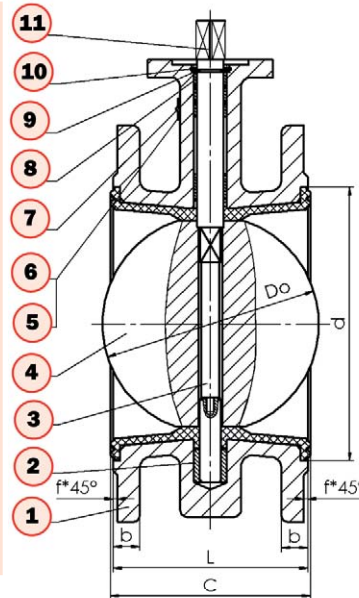

	50	65	80	100	125	150	200	250	300	350	400
A	120	130	145	155	170	190	205	235	280	310	340
B	80	89	95	114	125	139	170	198	223	254	306
H	25	25	25	25	25	25	25	30	30	30	36
D	165	135	200	220	250	285	340	395	445	505	580
K	125	145	160	180	210	240	295	350	400	460	525
N-d	4-19	4-19	8-19	8-19	8-19	8-23	8-23	12-23	12-23	16-23	16-31
Do	52,6	64,3	78,8	104	123,3	155,7	202,4	250,4	301,5	333,3	389,6
d	89	106	120	144	170	197	252	305	350	415	460
L	108	112	114	127	140	140	152	165	178	190	216
C	111	115	117	130	143	143	155	168	182	194	221
b	19	19	19	19	19	19	20	22	24,5	24,5	28
f	3	3	3	3	3	3	3	3	3	4	4
D1	65	65	65	90	90	90	125	125	125	150	175
D2	50	50	50	70	70	70	102	102	102	125	140
N-d1	4-7	4-7	4-7	4-10	4-10	4-10	4-12	4-12	4-12	4-14	4-18
F	13	13	13	13	13	13	15	15	20	20	22
Ø	12,6	12,6	12,6	15,77	18,92	18,92	22,1	28,45	31,6	31,6	37,95
W	14	14	14	14	17	17	17	22	22	27	27

*) PN16 upon request

22 / AB0 Valve Czech

DESIGN PARAMETERS

/ SERIES - „F”



DN450 - DN1200 / PN10

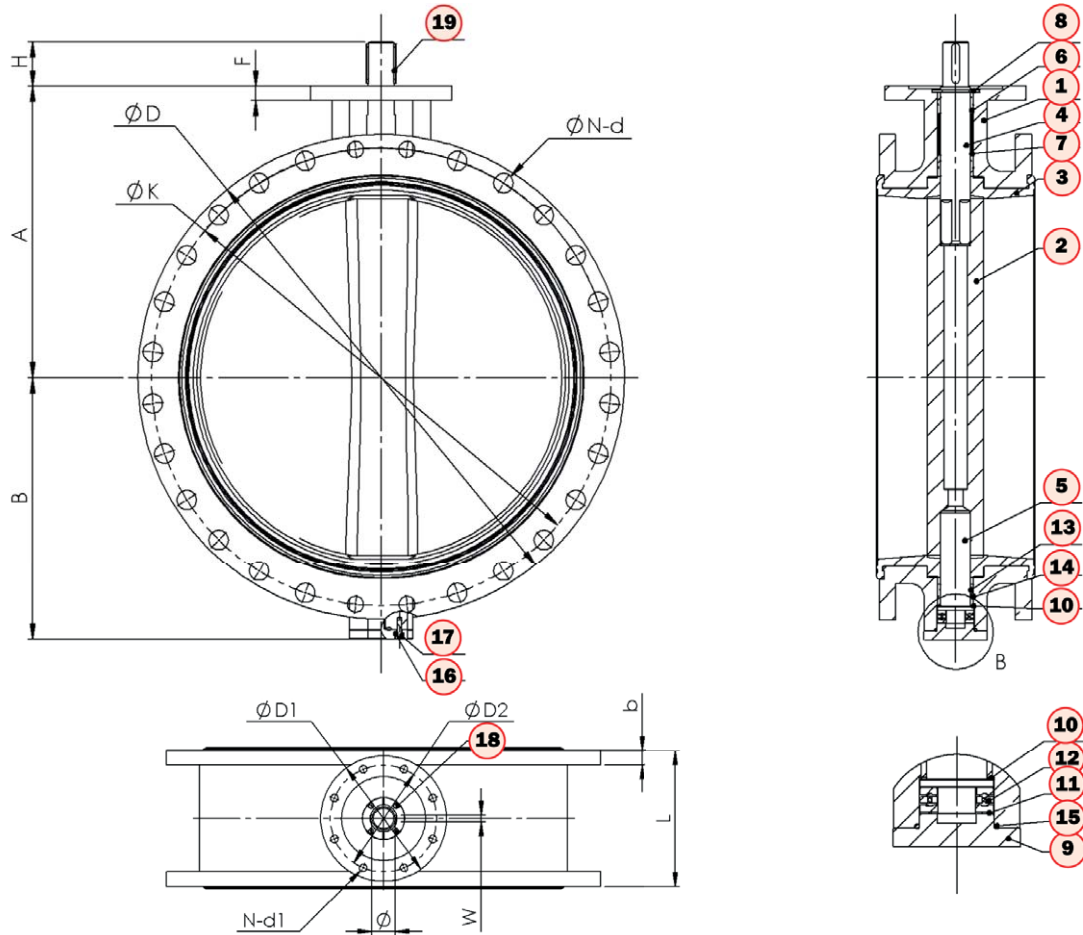

	450	500	600	700	800	900	1000	1200
A	375	430	500	560	620	685	735	917
B	345	378	440	510	560	638	705	815
H	80	80	80	95	95	130	130	150
D	615	670	780	895	1015	1115	1230	1455
K	565	620	725	840	950	1050	1160	1380
N-d	20-28	20-28	20-31	24-31	24-34	28-34	28-37	32-41
Do	440,5	491,6	592,5	695	794,7	864,7	965	1160,6
d	510	560	660	770	871	972	1080	1270
L	222	229	267	292	318	330	410	470
c	227	234	272	299	325	337	417	478
b	25,5	26,5	30	32,5	35	37,5	40	45
f	4	4	5	5	5	5	5	5
D1	175	175	210	300	300	300	300	350
D2	140	140	165	254	254	254	254	298
N-d1	4-18	4-18	4-22	8-18	8-18	8-18	8-18	8-22
F	22	22	22	30	30	34	34	34
\varnothing	38	42	50	55	55	75	85	105
W	10	12	14	16	16	20	22	28

*) sizes above DN1200 upon request.

*) PN16 on request

CONTACT US

Industrial Valve Manufacturer



Czech Republic

ABO valve, s.r.o.
Dalimilova 285/54
783 35 Olomouc
tel.: +420 585 222 232
sales@abovalve.com

Slovak Republic

ABO Slovakia, s.r.o.
Nové Mesto nad Váhom
tel.: +421 947 902 862
sales.sk@abovalve.com

Germany

ABO Armaturen GmbH
Essen
tel.: +49 (0)152 262 29501
sales.de@abovalve.com

Italy

ABO valve Italiana S.r.l.
Agrate Brianza
tel.: +39 334 9102143
sales.it@abovalve.com

USA

ABO Controls LLC
Houston
tel.: +(1) 832.291.4929
sales.us@abovalve.com

Ukraine

ABO Ukraine LLC
Dnipro
tel.: +38 056 733 95 70
sales.ua@abovalve.com

Turkey

ABO Armaturen LTD STI
Istanbul
tel.: +90 216 527 36 34
sales.tr@abovalve.com

India

ABO Controls Pvt. Ltd.
Pune
tel.: +91 97691 31034
sales.in@abovalve.com

Singapore

ABO Valve Pte. Ltd.
Singapore
tel.: +65 9169 4562
sales.sn@abovalve.com

China

ABO Flow Control
Shanghai
tel.: +86 136 01 522 831
sales.cn@abovalve.com

United Arab Emirates

Sales representation
Abu Dhabi
tel.: +971 56 9207964
bharti@abovalve.com

Bahrain

Sales representation
Manama
tel.: +973 3444 9065
jimmichen@abovalve.com



Follow us on:



www.abovalve.com



The technical information described in this leaflet is tentative and for general use only and does not constitute a recommendation or guarantee for any specific service or application requirement. Please consult ABO representative or factory for specific requirements and material selection for your intended application. The right to change or modify product design or product without prior notice is reserved. ABO valve accepts no liability for damages caused by bad interpretation or use of the information included in this brochure.

Valid from: 8/2024